

Stormwater Quality BMP Guidance Manual for Construction

Development Services Department





This document represents the City's recommendations for Best Management Practices relating to construction activities and stormwater runoff.

The Manual can be purchased at the City's Civic Center located at 311 Vernon Street, Permits Counter. It can also be downloaded from the City's website.

www.roseville.ca.us/gov/development_services/engineering_land_development/design_construction_standards.asp



This document was prepared by:
Public Works Department – Engineering Division
311 Vernon Street, Roseville, CA 95678
www.roseville.ca.us/pw
February 2011

INTENTIONALLY LEFT BLANK

TABLE OF CONTENTS

Section	Subject	Page
1.0	Executive Summary	6
2.0	Definitions and Acronyms	10
3.0	Stormwater Pollution Prevention Plan	20
4.0	Best Management Practices, Guidelines	28
4.1	Erosion and Sediment Control Practices	29
4.1.1	Scheduling	30
4.1.2	Erosion Control	31
	Preservation of Existing Vegetation	32
	Straw Mulch	33
	Broadcast Seed	34
	Hydro-seeding	35
	Hydraulic Mulch	36
	Soil Binders	37
	Wood Mulching	38
	Geo-textiles, Plastic Covers, Blankets & Mats	39
4.1.3	Stormwater Flow Diversion	40
	Earth Dikes, Drainage Swales and Ditches	41
	Slope Drains	42
4.1.4	Sediment Control	43
	Fiber Rolls	44
	Silt Fence	45
	Straw Bale Barrier	46
	Drain Inlet Protection	47
	Stabilized Construction Entrance/Exit	48
	Gravel Bag Berm	49
	Sediment Trap	50
	Check Dam	51
	Street Cleaning	52
	Wind Erosion and Dust Control	53
	Sediment Basins	55
	Active Treatment System (ATS)	57

4.2	Good Housekeeping Practices	60
4.2.1	Disposal of Construction Materials	61
	Concrete Finishing, Mortar and Masonry Work	62
	Concrete Washout Area	63
	Stucco Work and Painting	64
	Lime/Fly Ash and Cement Treating	65
4.2.2	Process Discharge Containment	66
	Boring Operations & Concrete Saw-Cutting	67
	Paving and Grinding Operations	68
	Dewatering Operations	69
4.2.3	Stream Protection	70
	Temporary Stream Crossing	71
	Stream Bank Stabilization	72
4.2.4	Site Management	73
	Water Conservation	74
	Liquid Pollutant Management	75
	Sanitary Septic Waste Management	76
	Vehicle & Equipment – Cleaning, Fueling, & Maint.	77
	Hazardous Waste Management	78
	Contaminated Soil, Fertilizers and Pesticides	79
	Solid Waste Management	80
	Stockpile Management	81
	Material Use Delivery and Storage	82
	Spill Prevention and Control	83

APPENDICES

(A) BMP Installation Details

MATS AND BLANKETS CHANNEL INSTALLATION DETAIL (BMP-1)	86
MATS AND GEOTEXTILE BLANKETS SLOPE INSTALLATION DETAIL (BMP-2)	88
EARTH DIKES AND SWALES INSTALLATION DETAIL (BMP-3)	90
SLOPE DRAINS INSTALLATION DETAIL (BMP-4)	92
FIBER ROLLS INSTALLATION DETAIL (BMP-5)	94

SILT FENCE INFORMATION DETAIL (BMP-6)	96
INLET SEDIMENT CONTROL INSTALLATION DETAIL (BMP-7)	98
DRAIN INLET FILTER BAG INSTALLATION DETAIL (BMP-8)	100
STABLIZED CONSTRUCTION SITE ACCESS INSTALLATION DETAIL (BMP-9)	102
CONCRETE WASHOUT INSTALLATION DETAIL (BMP-10)	104
STORM DRAIN INLET PROTECTION INSTALLATION DETAIL (BMP-11)	106
(B) City SWPPP Inspection Form	108
(C) City Enforcement Procedures for SWPPP	112

INTENTIONALLY LEFT BLANK

SECTION 1.0

EXECUTIVE SUMMARY

BACKGROUND

In 1972, the Federal government amended the Clean Water Act (CWA) to provide that the discharge of pollutants to waters of the United States from any point source is unlawful unless the discharge is in compliance with a National Pollution Discharge Elimination System (NPDES) permit.

Then in 1987 a new amendment to the Clean Water Act added Section 402(p), which established the framework for regulating municipal and industrial stormwater discharges under the NPDES program. On November 16, 1990, the U.S. Environmental Protection Agency (USEPA) published final regulations that established stormwater permit application requirements for specific categories of industries. The EPA's Phase I regulations provide that discharges of stormwater to waters of the United States from construction projects that encompass construction activities disturbing five acres or more of soil must meet compliance with an NPDES permit.

On December 8, 1999, the EPA published the NPDES Phase II regulations in the Federal Register as required by Section 402(p) of the CWA. NPDES Phase II regulations expanded the existing regulation on construction sites to any construction site one acre or greater of disturbed soil. The Phase II regulations also required that Small Municipal Separate Storm Sewer Systems (MS4s), such as the City of Roseville, comply with the requirements of the Clean Water Act to further protect streams, rivers and beaches from polluted runoff.

In response to the EPA's Phase II regulations, the State of California's Water Resources Control Board (SWRCB) established two General NPDES Permits to comply with these Federal mandates. One of the General Permits addressed construction site activities directly (Water Quality Order No. 2009-0009-DWQ). The other General Permit (Water Quality Order No. 2003-005-DWQ), regulates discharges from Small Municipal Separate Storm Sewer Systems (MS4s).

The City of Roseville (City) received its NPDES municipal stormwater permit from the SWRCB in July 2004. Under this permit, the City must implement to the "maximum extent practicable" six Minimum Control Measures including:

- Public Education and Outreach on Storm Water Impacts
- Public Involvement / Participation
- Illicit Discharge Detection and Elimination
- Construction Site Stormwater Runoff Control
- Post-Construction Storm Water Management in New Development and Redevelopment
- Pollution Prevention / Good Housekeeping for Municipal Operations

The City's Stormwater Management Plan (SWMP) identifies the work to be undertaken by the City to implement each of the six Minimum Control Measures. Included in these tasks is the development of various Best Management Practices (BMP) Guidance Manuals to help the City, development community, and businesses comply with the City's stormwater program.

STORMWATER QUALITY BMP GUIDANCE MANUAL FOR CONSTRUCTION

The City has developed this Guidance Manual to provide the development community with clear instruction for stormwater quality compliance on construction sites. This document is divided into five sections:

- Section 1 – Executive Summary
- Section 2 – Definitions and Acronyms
- Section 3 – Stormwater Pollution Prevention Plans
- Section 4 – Best Management Practices (BMP) Guidelines
- Appendix – Details and Forms

Section 1 – Executive Summary

The Executive Summary provides background for this document and summarizes what information is found within each section of this Guidance Manual.

Section 2 – Definitions and Acronyms

This section provides a list of commonly used words in Stormwater Quality and their definitions that are found in the Guidance Manual. Also, included are definitions of commonly used acronyms.

Section 3 – Stormwater Pollution Prevention Plans (SWPPP's)

Section 3 provides the requirements for the preparation and submittal of a Stormwater Pollution Prevention Plans (SWPPP) for construction activities. This section details the City's and the State's procedural requirements for SWPPP submittals and site inspections related to stormwater quality.

Section 4 – Best Management Practices (BMP) Guidelines

The Best Management Practices Guidelines portion of this Guidance Manual, Section 4, identifies the various construction related BMP's that can be used within the City of Roseville to control construction site run-off. For there to be effective discharge control from a construction site, the selection of BMP's used and the installation of the BMP's are important. This section addresses issues such as erosion control, sediment control and good house keeping practices.

Appendix – Details and Forms

Details for proper BMP installations and various City forms related to this element of the City's Stormwater Management Program are provided in the Appendix "A".

REFERENCES

Various agency publications were referenced for the information contained herein. Substantial reference was made (and material condensed and revised) from the California Stormwater Quality Association (CASQA) "Stormwater Best Management Practice Handbook for Construction" and the "Caltrans Best Management Practice (BMP) Field Manual and Trouble Shooting Guide". These Manuals are available on-line at the following web addresses:

www.cabmphandbooks.com

www.dot.ca.gov/hq/construc/stormwater/BMP_Field_Master_FullSize_Final-Jan03.pdf

Additional information available on the web

City of Roseville Construction Stormwater Program:

http://www.roseville.ca.us/pw/engineering/stormwater/post_construction_run_off_control.asp

Placer County Air Pollution Control District:

www.placer.ca.gov/Departments/Air/airquality.aspx

Placer County Stormwater Management Manual:

www.placer.ca.gov/Works/Resources/Swmm.aspx

Placer County Vector Control District

www.placermosquito.org/index.php

California Department of Fish & Game

www.dfg.ca.gov

INTENTIONALLY LEFT BLANK

SECTION 2.0

DEFINITIONS AND ACRONYMS

DEFINITIONS

303(d) Listed: Water bodies listed as impaired as per Section 303(d) of the 1972 Clean Water Act. This list is updated by the State of California and approved by the EPA as needed.

Active Treatment System (ATS): A treatment system that employs chemical coagulation, chemical flocculation, or electrocoagulation to aid in the reduction of turbidity caused by fine suspended sediment.

Best Management Practices (BMP's): Includes schedules of activities, prohibitions of practices, maintenance procedures, and other management practices to prevent, eliminate, or reduce the pollution of waters of the receiving waters. BMP's also include treatment requirements, operating procedures, and practices to control plant site runoff spillage or leaks, sludge or waste disposal, or drainage from raw material storage.

Catch Basin (Also known as Drain Inlet or DI): Box-like underground concrete structure with openings in curbs and gutters designed to collect runoff from streets and pavement.

Clean Water Act (CWA): (33 U.S.C. 1251 et seq.) requirements of the NPDES program are defined under Sections 307, 402, 318 and 405 of the CWA.

Construction Activity: Includes clearing, grading, excavation, and contractor activities that result in soil disturbance.

Construction General Permit: A National Pollution Discharge Elimination System (NPDES) permit (No. CAS000002) issued by the State Water Resources Control Board for the discharge of stormwater associated with construction and land disturbance activities of one acre or more (Order No. 2009-0009-DWQ).

Denuded: Land stripped of vegetation or land that has had its vegetation worn down due to the impacts from the activities and humans.

Detention: The capture and subsequent release of stormwater runoff from the site at a slower rate than it is collected, the difference being held in temporary storage.

Discharge: A release or flow of stormwater or other substance from a conveyance system or storage container. Broader – includes release to storm drains, etc.

Direct Discharge: A discharge that is routed directly to waters of the United States by means of a pipe, channel, or ditch (including a municipal storm sewer system), or through surface runoff. Discharges from a construction site to a MS4 where commingling with upstream and/or downstream discharges can occur are not considered direct discharges.

Disturbed Soil Area (DSA): Areas of soil disturbance cause by human activity such as construction, agriculture, or forestry practices.

Drainage Area: The area of land that drains water, sediment, pollutants, and dissolved materials to a common outlet.

Effluent: Any discharge of water by the discharger either to the receiving water or beyond the property boundary controlled by the discharger.

Effluent Limitation: Any numeric or narrative restriction imposed on quantities, discharge rates, and concentrations of pollutants which are discharged from point sources into waters of the United States, the waters of the contiguous zone, or the ocean.

Erosion: The process, by which soil particles are detached and transported by the actions of wind, water, and/or gravity.

Erosion Control BMP's: Vegetation, such as grasses and wildflowers, and other materials, such as straw, fiber, stabilizing emulsion, protective blankets, etc., placed to stabilize areas of disturbed soils, reduce loss of soil due to the action of water or wind, and prevent water pollution.

Facility: Is a collection of industrial processes discharging stormwater associated with industrial activity within the property boundary or operational unit.

Field Measurements: Testing procedures performed in the field with portable field-testing kits or meters.

Grading: The displacement of soil by cutting or filling surface areas to meet a desired slope and/or surface elevation.

Hazardous Waste: A waste or a combination of wastes that, because of its quantity, concentration, or physical, chemical or infectious characteristics, may either cause or significantly contribute to an increase mortality or an increase in serious irreversible illness; or pose a substantial present or potential hazard to human health or the environment when improperly treated, stored, transported, disposed of or otherwise managed. Possesses at least one of the four characteristics (ignitability, corrosively, reactivity or toxicity) or appears on special EPA or state list, Regulated under the Federal Resource Conservation and Recovery Act and the California Health and Safety Code.

Illicit Discharges: Any discharge to a municipal separate storm sewer that is not in compliance with applicable laws and regulations as discussed in this document.

Industrial General Permit: A National Pollutant Elimination System (NPDES) Permit (No. CAS000001) issued by the State Water Resources Control Board for discharge of stormwater associated with industrial activity. Board Order 97-03-DWQ.

Inlet: An entrance into a ditch, storm drain, or other waterway

Likely Precipitation Event: Any weather pattern that is forecasted to have a 50% or greater chance of producing precipitation in the project area. The discharger shall obtain likely precipitation forecast information from the National Weather Service Forecast Office (e.g. by entering the zip code on the project's location at www.srh.noaa.gov/forecast).

Manual: The City of Roseville "Stormwater Quality BMP Guidance Manual for Construction".

Municipal Separate Storm Sewer System (MS4): A conveyance or system of conveyances (including roads with drainage systems, municipal streets, catch basins, curbs, gutter, ditches, man-made channels, or storm drains): (i) design or used for collecting or conveying storm water; (ii) which is not a combined sewer; and (iii) which is not part of a Publicly Owned

Treatment Works (POTW) as defined at Title 40 of the Code of Federal Regulations (CFR) 122.2. A “Small MS4” is defined as an MS4 that is not a permitted MS4 under the Phase I regulations. This definition of a Small MS4 applies to MS4 systems operated within cities and counties as well as governmental facilities that have storm sewers.

Non-Stormwater Discharge: Any discharge to municipal separate storm sewer that is not composed entirely of stormwater.

Non-point Source Pollution: Pollution that does not come from a point source. Non-point source pollution originates from aerial diffuse sources that are mostly related to land use.

Notice of Intent (NOI): A formal notice to SWRCB submitted through the State Water Board’s Storm Water Multi-Application and Report Tracking System (SMARTS) website by the owner of a construction site that said owner seeks coverage under a General Permit for discharges associated with construction activities. The NOI provides information on the owner, location, type of project, and certifies that the owner will comply with the conditions of the Construction General Permit.

Notice of Termination (NOT): Formal notice to SWRCB submitted through the SMARTS website by owner, or Legal Responsible Person (LRP) that a construction project is complete.

NPDES Permit: NPDES is an acronym for National Pollution Discharge Elimination System. NPDES is the national program for administering and regulating Sections 307, 318, 402 and 405 of the Clean Water Act (CWA). In California, the state Water Resources Control Board (SWRCB) has issued a General Permit for stormwater discharges associated with industrial activities (see List of Acronyms).

Numeric Action Level (NAL): A measurement or range used as a warning to evaluate if best management practices are effective, or require necessary corrective actions. Not to be confused with an effluent limit. For stormwater compliance on construction sites, pH and turbidity are monitored (Order No. 2009-0009-DWQ, Section V. EFFLUENT STANDARDS, C).

Numeric Effluent Limitation (NEL): A measurement or range used as a limit at which an exceedance thereof constitutes a violation of the Construction General Permit (Order No. 2009-0009-DWQ, Section V. EFFLUENT STANDARDS, B).

Outfall: The end point where storm drains discharge water into a waterway.

pH: Unit universally used to express the intensity of the acid or alkaline condition of a water sample. The pH of natural waters tends to range between 6 and 9, with neutral being 7. Extremes of pH can have deleterious effects on aquatic systems.

Point Source: Any discernable, confined, and discrete conveyance from which pollutants are or may be discharged. This term does not include return flows from irrigated agriculture or agricultural stormwater runoff.

Pollutant: Generally, any substance introduced into the environment that adversely affects the usefulness of a resource.

Pollution Prevention (P2): Practices and actions that eliminate or reduce the generation of pollutants.

Post-Construction BMP's: Structural and non-structural controls which detain, retain, or filter the release of pollutants to receiving waters after construction is complete and final stabilization is attained.

Precipitation: Any form of rain or snow.

Pretreatment: Treatment of waste stream before it is discharged to a collection system.

Qualifying Rain Event: Any event that produces 0.5 inches or more of precipitation with a 48 hour or greater period between rain events.

Qualified SWPPP Developer (QSD): Individual who is authorized per the requirements of Order No. 2009-0009-DWQ to develop and revise SWPPP's.

Qualified SWPPP Practitioner (QSP): Individual assigned responsibility by the owner for non-storm water and storm water visual observations, sampling and analysis, and responsibility to ensure full compliance with the Construction General Permit and implementation of all elements of the SWPPP, including the preparation of the annual compliance evaluation and the elimination of all unauthorized discharges.

Receiving Waters: The Waters of the U.S. that includes surface and ground waters..

Reclaim (water reclamation): Planned use of treated effluent that would otherwise be discharged without being put to direct use.

Revised Universal Soil Loss Equation (RUSLE): Empirical model that calculates average annual soil loss as a function of rainfall and runoff erosivity, soil erodibility, topography, erosion controls, and sediment controls.

Retention: The storage of stormwater to prevent it from leaving the development site.

Reuse (water reuse): (see Reclaim)

Runoff: Water originating from rainfall, melted snow, and other sources (e.g., sprinkler irrigation) that flows over the land surface to drainage facilities, river, streams, spring, seeps, pond, lakes, and wetlands.

Run-on: Off site stormwater surface flow or other surface flow which enters your site.

Sampling and Analysis Plan: Document that describes how the samples will be collected, under what conditions, where and when the sample will be collected, what the sample will be tested for, what test methods and detection limits will be used, and what methods/procedures will be maintained to ensure the integrity of the sample during collection, storage, shipping and testing (e.g., quality assurance/quality control protocols).

Scour: The erosive and digging action in a watercourse caused by flowing water.

Secondary Containment: Structures, usually dikes or berms, surrounding tanks or other storage containers, designed to catch spilled material from storage containers.

Sediment: Solid particulate matter, both mineral and organic, that is in suspension, being transported, and/or moved from it's site of origin by air, water, gravity, or ice and has come to rest on the earth's surface either above or below sea level.

Sedimentation: The process of depositing soil particles, clays, sands, or other sediments that were picked up by runoff.

Sediment Control BMP's: Practices that trap soil particles after they have been eroded by rain, flowing water, or wind. They include those practices that intercept and slow or detain the flow of storm water to allow sediment to settle and be trapped (e.g., silt fence, sediment basin, fiber rolls, etc.).

Settleable Solids (SS): Solid material that can be settled within a water column during a specified time frame. It is typically tested by placing a water sample into an Imhoff settling cone and then allowing the solids to settle by gravity for a given length of time. Results are reported either as a volume (mL/L) or a mass (mg/L) concentration.

Sheet Flow: Flow of water that occurs overland in areas where there are no defined channels where the water spreads out over a large area at a uniform depth.

Significant Materials: Includes, but not limited to, raw materials such as solvent, detergents, and plastic pellets; finishing materials such as metallic products; raw materials used in food processing or production; hazardous substances designed under Section 101(14) of CERLCA; any chemical the facility is required to report pursuant to Section 313 Title III of SARA; fertilizers; pesticides; and waste products such as ashes, slag and sludge that have the potential to be released with stormwater discharges.

Significant Quantities: The volume, concentrations or mass of a pollutant in stormwater discharge that can cause or threaten to cause pollution, contamination, or nuisance that may adversely impact human health or the environment, and cause or contribute to, a violation of any applicable water quality standards for receiving water.

Soil Amendment: Any material that is added to the soil to change its chemical properties, engineering properties, or erosion resistance that could become mobilized by storm water.

Source Control BMP's: Operational practices that reduce potential pollution at the source.

Source Reduction (also source control): The technique of stopping and / or reducing pollutants at their point of generation so that they do not come into contact with stormwater.

Storm Drains: Above-and below-ground structures for transporting stormwater to streams or outfall for flood control purposes.

Stormwater: Defined as urban runoff and snowmelt runoff consisting only of those discharges, which originate from precipitation events. Stormwater is that portion of precipitation that flows across a surface to the storm drain system or receiving waters.

Stormwater Discharge Associated with Industrial Activity: Discharge from any conveyance which is used for collecting and conveying stormwater from an area that is directly related to manufacturing, processing, or raw materials storage activities at an industrial plant.

Stormwater Pollution Control Plan (SWPCP): A less formal plan than a SWPPP that addresses the implementation of BMP's at facilities/ businesses not covered by a general permit but that have the potential to discharges pollutants.

Stormwater Pollution Prevention Plan (SWPPP): A written plan that documents the series of phases and activities that, first, characterizes your site, and then prompts you to select and carry out actions which prevent the pollution of stormwater discharges.

Suspended Sediment Concentration (SSC): The measure of the concentration of suspended solid material in a water sample by measuring the dry weight of all of the solid material from a known volume of a collected water sample. Results are reported in mg/L.

Treatment Control BMP's: Treatment methods to remove pollutants from stormwater.

Total Suspended Solids (TSS): The measure of the suspended solids in a water sample includes inorganic substances, such as soil particles and organic substances, such as algae, aquatic plant/animal waste, particles related to industrial/sewage waste, etc. The TSS test measures the concentration of suspended solids in water by measuring the dry weight of a solid material contained in a known volume of a sub-sample of a collected water sample. Results are reported in mg/L.

Toxicity: Adverse responses of organisms to chemicals or physical agents ranging from mortality to physiological responses such as impaired reproduction or growth anomalies.

Turbidity: The cloudiness of water quantified by the degree to which light traveling through a water column is scattered by the suspended organic and inorganic particles it contains. The turbidity test is reported in Nephelometric Turbidity Units (NTU) or Jackson Turbidity Units (JTU).

Waters of the United States: Generally refers to surface waters, as defined by the Federal Environmental Protection Agency in 40 C.F.R. § 122.2.1.

Water Quality Objectives (WQO): Water quality objectives are defined in the California Water Code as limits or levels of water quality constituents or characteristics, which are established for the reasonable protection of beneficial uses of water or the prevention of nuisance within a specific area.

ACRONYMS

AC	Asphalt Concrete
ATS	Active Treatment System
AIMP	Impervious Area
AINF	Infiltration Area
ANSI	American National Standards Institute
AQMD	Air Quality Management District
ASTM	American Society for Testing Materials
BAT	Best Available Technology Economically Achievable
BCT	Best Conventional Pollutant Control Technology
BFM	Bonded Fiber Matrix
BMP's	Best Management Practices
BOD	Biochemical Oxygen Demand
BPJ	Best Professional Judgment
CAL-EPA	California Environmental Protection Agency
CAL-OSHA	California Division of Occupational Safety & Health Administration
CASQA	California Stormwater Quality Association
CEQA	California Environmental Quality Act
CGP	NPDES General Permit for Storm Water Discharges Associated with Construction Activities
COC	Chain of Custody
COI	Change of Information
CPESC	Certified Professional in Erosion and Sediment Control
CPSWQ	Certified Professional in Storm Water Quality
CSMP	Construction Site Monitoring Program
CWA	Clean Water Act
CWC	California Water Code

DCIA	Directly Connected Impervious Area
DFG	Department of Fish and Game
DSA	Disturbed Soil Area
EIR	Environmental Impact Report
EPA	Environmental Protection Agency
ESA	Environmentally Sensitive Area
ESC	Erosion and Sedimentation Control
ESCP	Erosion and Sediment Control Plan
FEMA	Federal Emergency Management Agency
GIS	Geographical Information System
Hazmat	Hazardous Material
HSG	Hydrologic Soil Groups
JTU	Jackson Turbidity Units
LID	Low Impact Development
LRP	Legally Responsible Person
LUP	Linear Underground/Overhead Projects
MATC	Maximum Allowable Threshold Concentration
MDL	Method Detention Limit
MEP	Maximum Extent Practicable
MRR	Monitoring and Reporting Requirements
MS4	Municipal Separate Storm Sewer System
MSDS	Material Safety Data Sheet
MUSLE	Modified Universal Soil Loss Equation
NAL	Numeric Action Level
NEL	Numeric Effluent Limitation
NOAA	National Oceanic and Atmospheric Administration
NOI	Notice of Intent

NOT	Notice of Termination
NOV	Notice of Violation
NPDES	National Pollutant Discharge Elimination System
NPS	Non-point Source
NTU	Nephelometric Turbidity Unit
O&G	Oil and Grease
O&M	Operations and Maintenance
OSDS	On-site Disposal System
OSHA	Occupational Safety and Health Administration
P2	Pollution Prevention
PAC	Polyaluminum chloride
PAHs	Polyaromatic Hydrocarbons
PAM	Polyacrylamide
PCB's	Polychlorinated Biphenyls
PCC	Portland Concrete Cement
POC	Pollutants of Concern
PoP	Probability of Precipitation
POTW	Publicly Owned Treatment Works
PPT	Pollution Prevention Team
PRDs	Permit Registration Documents
PSD	Particle Size Distribution
QA/QC	Quality Assurance/Quality Control
QSD	Qualified SWPPP Developer
QSP	Qualified SWPPP Practitioner
REAP	Rain Event Action Plan
RNOV	Roseville Notice of Violation

RUSLE	Revised Universal Soil Loss Equation
RW	Receiving Water
RWQCB	Regional Water Quality Control Board
SAP	Sampling and Analysis Plan
SMARTS	Storm Water Multi Application Reporting and Tracking System
SS	Settleable Solids
SSC	Suspended Sediment Concentration
SWMP	Stormwater Management Plan
SWPCP	Stormwater Pollution Control Plan
SWPPP	Stormwater Pollution Prevention Plan
SWRCB	State Water Resources Control Board
TDS	Total Dissolved Solids
TMDL	Total Maximum Daily Load
TOC	Total Organic Carbon
TSS	Total Suspended Solids
UFC	Uniform Fire Code
USACE	United State Army Corp of Engineers
USDA	United States Department of Agriculture
USDOT	United States Department of Transportation
USEPA	United States Environmental Protection Agency
WEF	Water Environment Federation
Wet Season	October 1 st through April 30 th
WDID	Waste Discharge Identification Number
WPCM	Water Pollution Control Manager
WPCP	Water Pollution Control Program
WQS	Water Quality Standard

SECTION 3.0

STORM WATER POLLUTION PREVENTION PLAN (SWPPP)

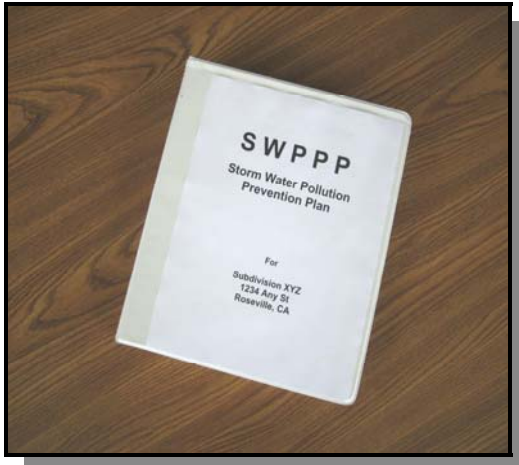

OVERVIEW

Prior to March 2003, only stormwater discharges from construction sites disturbing five acres or more were regulated under state and federal laws. Amendments to the federal law in 1999 reduced this construction site size exemption. Now, every construction site that disturbs **one acre or more**, or is less than one acre but part of a larger common plan that would disturb one acre or more, must comply with the State of California's General Permit (CGP) for Stormwater Discharges Associated with Construction Activities (Order No. 2009-0009-DWQ).

Stormwater discharges from activities such as clearing, grading, stock piling, utility underground, or excavation work are regulated under the State CGP and the City of Roseville Stormwater Quality Management Discharge Control Ordinance. Non-stormwater discharges from construction sites are also monitored as they can also transport pollutants to local waterways. Construction wastes, such as the following, must be managed properly during construction to prevent runoff pollution:

- Discarded building materials
- Concrete truck washout
- Mortar waste
- Stucco waste
- Paints
- Chemicals
- Litter & Debris
- Sanitary waste

STATE CONSTRUCTION PERMIT COVERAGE

It is the responsibility of the landowner to obtain State CGP coverage for planned construction activities **prior** to the commencement of work. To apply for coverage, the landowner, or his/her Legal Responsible Person (LRP) must electronically submit through the State's Storm Water Multiple Application and Report Tracking System (SMARTS), a Notice of Intent (NOI), a SWPPP, and other documents required by the CGP, and mail the appropriate fee to the SWRCB. This request to the State will provide, if approved, coverage under the State's General NPDES permit for construction activities. Coverage under the permit is not complete until a SWPPP and Permit Registration Documents (PRD's) are electronically submitted, the appropriate fee is paid, and a Waste Water Identification Number (WDID) is assigned by the RWQCB.

The General Permit for Construction Activity requires the SWPPP address water pollution control during construction. The SWPPP must outline the Best Management Practices (BMP's) planned for use on the site to prevent pollutants from leaving the project site. The BMP's should include, but are not limited to:

- Erosion controls
- Wind erosion controls
- Sediment controls
- Non-stormwater runoff controls
- Tracking controls
- Waste management controls
- Materials pollution controls
- Advanced treatment methods

For detailed BMP information including a SWPPP template, see the California Stormwater Quality Association (CASQA) web site at: www.cabmphandbooks.com. For online training courses based on the CASQA handbooks, go to the California State University web site at: www.owp.csus.edu/research/bmpcourses.

PROJECTS ONE ACRE OR MORE

The City's existing Grading Ordinance requires the submission of a grading plan prior to breaking ground at a construction site. Along with this requirement, the City's Development Services Department requires the submission of a SWPPP prior to the issuance of an Improvement Plan, Grading Permit or Encroachment Permit. The following procedures apply to construction sites that disturb one acre or more of land or are part of a larger project that disturbs one acre or more.

1. The landowner or LRP shall submit PRD's to the SWRCB in compliance with the NPDES General Stormwater Construction Permit before construction commences. The following steps are provided as guidance for obtaining State permit coverage:

- Access the SWRCB Stormwater Multi Application Reporting and Tracking (SMARTS) website at: www.swrcb.ca.gov/stormwtr/construction.html
- Electronically submit all required PRD's which include but are not limited to:
 1. Notice of Intent
 2. Risk Assessment (Standard or Site –Specific)
 3. Site Map
 4. SWPPP
 5. Signed Certification Statement

- Mail the appropriate annual fee, to the State Water Board via certified mail no later than seven days prior to commencement of construction activities.
 - Permit coverage shall not commence until the PRD's and the annual fee are received by the State Water Boards, and a WDID number is assigned and sent by SMARTS.
 - Complete a hard copy of the site specific SWPPP identical to that uploaded to the SMARTS, and submit it to the City of Roseville at the same time Improvement Plans are submitted.
2. The SWPPP, as described in the CASQA Handbook for Construction requires the use of stormwater BMP's tailored to the circumstances of a particular site or project. The SWPPP has two main objectives: 1) identify pollutant sources, and 2) describe practices to reduce sediment transport of pollutants in stormwater discharges. Specific requirements can be obtained from the RWQCB, and at the following website: <http://www.cabmphandbooks.com>.
 3. The Applicant shall submit a complete SWPPP to the City's Development Services Department, Engineering - Land Development Division concurrent with the Improvement Plan review and approval process. Submittal of the SWPPP shall be a condition of the Improvement Plan, Grading Permit and Encroachment Permit issuance. The hard copy SWPPP shall be submitted to the City in a three ring binder. Only one set is required.
 4. The City's Development Section Staff will then perform a cursory review of the SWPPP for completeness, general conformance, and adherence for the following objectives:
 - All pollutants and their sources, including sources of sediment associated with construction, construction site erosion and all other activities associated with construction activity are controlled;
 - Where not otherwise required to be under a RWQCB permit, all non-storm water discharges are identified and either eliminated, controlled, or treated;
 - Site BMP's are effective and result in the reduction or elimination of pollutants in storm water discharges and authorized non-storm water discharges from construction activity to the BAT/BCT standard;
 - Calculations and design details as well as BMP controls for site run-on are complete and correct, and
 - BMP's installed to reduce or eliminate pollutants after construction are completed and maintained.

The site specific SWPPP shall also include:

- Vicinity Map showing nearby roadways, the construction site perimeter and geographic features and general topography surrounding the site.

- A site map showing the construction project in detail including site layout, construction site boundaries, drainage areas, discharges locations, sampling locations, areas of soil disturbance (temporary or permanent), active areas of soil disturbance (cut or fill), locations of all runoff BMP's, a description of the type and location of erosion control and sediment control BMP's, Active Treatment System (ATS) location (if applicable), locations of sensitive habitats, watercourses, or other features which are not to be disturbed, locations of all post-construction BMP's, and locations of storage areas for waste, vehicles, service, loading/unloading of materials, access (entrance/exits) points to construction site, fueling, water storage, and water transfer for dust control and compaction practices.
 - A detailed, site-specific listing of the potential sources of stormwater pollution.
 - Identify and provide methods to implement BMP inspection, visual monitoring, Rain Event Action Plan (REAP) and Construction Site Monitoring Program (CSMP) requirements to comply with the Construction General Permit.
 - The name and telephone number of the Qualified SWPPP Practitioner (QSP) responsible for implementing the SWPPP.
 - Certification/signature by the landowner/LRP and the Qualified SWPPP Developer (QSD) responsible for developing the SWPPP.
 - A WDID number assigned by the RWQCB,
5. Once the Development Section records the SWPPP and determines completeness, an acknowledgment sheet is inserted into the SWPPP binder, as well as a tabbed divider, at the rear of the binder for on-site City staff and contractor reference. This document will then be forwarded to the assigned Stormwater Inspector (SWI) along with the approved improvement plans. A pre-construction meeting date may be scheduled by the Applicant following approval of the SWPPP, Improvement Plans, Grading and Encroachment Permit. A pre-construction meeting agenda may be forwarded to the Applicant upon request.
 6. Both the Stormwater and Construction Inspectors' may be present at the pre-construction meeting to discuss contractor expectations for SWPPP compliance. City inspection staff will return the SWPPP binder to the project's QSP during the meeting. The SWPPP must be kept on-site for the duration of the entire construction phase of the project. The inspectors will explain the City's construction stormwater runoff inspection and enforcement procedures during this meeting. Project compliance procedures required of the QSP, QSD and/or the LRP will include, but are not limited to:
 - A) Keeping the project SWPPP up to date and at the job site.
 - B) Inspect all BMP's before, during and after rain events. Keep written comments on failures and corrections.
 - C) SWPPP site plan shall be kept current showing changes and updates.
 - D) Properly install and maintain BMP's.
 - E) Practice good housekeeping.

- F) Eliminate or minimize tracking from construction entrances and exits by utilizing an all- weather rock entrance (see Detail BMP – 9).
 - G) Sweep/vacuum streets and obtain clearance from Construction Inspector before washing.
 - H) Contain and/or treat wash water from power washing operations and dispose of it appropriately.
 - I) Maintain drain inlet protection liners and bags, and ensure that the area around storm drains is kept clean.
 - J) Develop and implement a REAP 48 hours prior to any likely precipitation event (A likely precipitation event is any weather pattern that is forecast to have a 50% or greater probability of producing precipitation in the project area per the National Weather Service Forecast Office.
 - K) Electronically submit all sampling, exceedance, and annual reporting; all change of information (COI), and any revisions or amendments to the project SWPPP to the SWRCB through the SMARTS website.
 - L) State Construction General Permit coverage will include additional requirements within the SWPPP. (Refer to Order No 2009-0009-DWQ)
7. City staff will conduct stormwater inspections once a week during the construction process. Site visits will consist of completing the standard City Stormwater Inspection Form, (available on the City's web page). An electronic copy of the Stormwater Inspection Form will be emailed to the project site's QSP. The QSP can print a copy of the inspection report to be inserted in the tabbed section of the SWPPP binder, or the report can be filed electronically. Whichever method is used is acceptable as long as the report can be reproduced at the request of either any Roseville, or RWQCB inspection staff member. It shall be the QSP's responsibility to confirm the copy of the Stormwater Inspection Report is reviewed and filed appropriately, and to correct reported non-compliance issues weekly or as directed. If reports are missing, the site maybe issued a non-compliance inspection report.
- If violations are found by the inspector, the QSP will be notified of the violation. The City of Roseville will provide at the pre-construction meeting the City's enforcement procedures for stormwater quality violations. Also, the RWQCB staff may also intermittently inspect sites for stormwater runoff compliance and consult with City stormwater inspection staff. The QSP is encouraged to participate in the site inspections with the Stormwater or Construction Inspector. It is essential, in a timely manner, to address the control of all potentially polluted runoff from the site together, as a team, the City Inspector and the owner's QSP.
8. City Inspectors may conduct construction site inspections prior to anticipated storms, after storm events, and every 24 hours during extended storms, as well as other times, to find areas contributing to stormwater discharge and to determine if the requirements of the site SWPPP are adequate and properly implemented. The QSP is required, under the State permit, to perform pre and post storm inspections, as well as weekly inspections throughout the entire year. The discharger must immediately make corrections if it is found after a storm that BMP's are damaged or inadequate for protection of water quality.

The City's Floodplain Management Section provides e-mail weather reports and anticipated storm information at least three days prior to storm events to the City Inspection staff. This data is used to aid each Inspector in the inspection and enforcement of City's stormwater quality requirements for construction activities.

9. City Inspectors will also review SWPPP binders for completeness, BMP adequacy, as well as weekly and pre and post inspections documented by the contractor. On-site SWPPP binders need to be kept current with site conditions, and shall include full descriptions that explain any changes made to the original plan. The SWPPP is a dynamic document, which is likely to change throughout the construction process. City Inspectors will perform stormwater quality inspections once a week at a minimum.
10. The Owner/QSP is responsible for correcting BMP deficiencies immediately. When appropriate, a written or verbal notice of non-compliance will be given to the QSP via the City's Inspection Report, City Inspector, or Regional Board staff. Continued non-compliance at a site will provide justification for the City to issue a Roseville Notice of Violation (RNOV) which could result in suspending inspections and/or issuing a Stop Work Notice, including recommendation to the RWQCB to inspect the site for violations.
11. Upon completion of the construction phase, the Applicant shall terminate the specific coverage under the CGP by submitting via the SMARTS a Notice of Termination (NOT) to the RWQCB that certifies that:
 - Construction activity is completed.
 - All parts of the SWPPP have been completed.
 - Construction and equipment maintenance waste have been disposed of properly.
 - The site complies with all local stormwater management requirements.
 - All disturbed areas of the construction site are stabilized per the General Permit.

Along with submitting to the State a NOT, the owner must remove all temporary construction BMP's: drop inlet filter bags, fiber rolls (wattles), and gravel bags. Additional required clean-up includes the removal of any sediment that has collected in the storm drain system or around any of the storm drain inlets.

12. The discharger may reduce or increase the total acreage covered under this General Permit when a portion of the site is complete and/or conditions for termination of coverage has been met; when ownership of a portion of the site is sold to a different entity; or when new acreage, subject to this General Permit, is added to the site. Within 30 days of a reduction or increase in total disturbed acreage, the discharger shall electronically file revisions to the PRD's that include:
 - A revised NOI indicating the new project size;
 - A revised site map showing the acreage of the site completed, acreage currently under construction, acreage sold/transferred or added, and acreage currently stabilized in accordance with the Conditions for Termination of Coverage in Section II.D below.
 - SWPPP revisions, as appropriate; and
 - Certification that any new landowners have been notified of applicable requirements to obtain General Permit coverage. The certification shall include

the name, address, telephone number, and e-mail address of the new landowner.

- If the project acreage has increased, dischargers shall mail payment of revised annual fees within 14 days of receiving the revised annual fee notification.
- The discharger shall continue coverage under the General Permit for any parcel that has not achieved “Final Stabilization”.
- When an LRP owns property with active General Permit coverage and the LRP sells the property, or a parcel thereof, to another person, that person shall become an LRP with respect to whatever parcel was sold. The existing LRP shall inform the new LRP of the General Permit’s requirements. In order for the new LRP to continue the construction activity on its parcel of property, the new LRP, or the new LRP’s approved signatory, must submit PRD’s in accordance with this General Permit’s requirements.

13. The Discharger is responsible for maintaining SWPPP records for three years. Quarterly and annual reports are also requirements of the Construction General Permit. More specific information on report requirements can be obtained from accessing Section XVI, Annual Reporting Requirements (Order No 2009-0009-DWQ).

PROJECTS LESS THAN ONE ACRE

SWPPP’s and State NPDES permits are not required for projects under one acre within the City, unless they are part of a larger development encompassing over one acre, in which case, the procedures listed above are required. For projects less than one-acre, an erosion and sediment control plan shall be submitted with the improvement plans to the City for approval. This is generally part of the Grading Plan for the development. The Development Services Department, Engineering - Land Development Division, will approve the erosion and sediment control plan upon review of the project. All erosion and sediment control devices shall be identified and implemented in the same fashion as projects with SWPPP’s over one acre. Enforcement will be conducted similarly, with exception to SWPPP administrative requirements.

ENFORCEMENT PROCEDURES

The City of Roseville has enacted the Urban Stormwater Quality Management and Discharge Control Ordinance. This ordinance prohibits polluted stormwater discharges from entering the City’s storm drainage system, watercourse, natural outlet or channel. The ordinance also provides the City with the authority to make inspections to enforce provisions of the ordinance, and to enforce the provisions through the issuance of citations. See Appendix C of the Stormwater Quality BMP Guidance Manual for Construction for the City’s enforcement procedures and enforcement process flowchart. Additional information pertaining to inspections is provided in items 7 through 10 above.

ABANDONED/INACTIVE CONSTRUCTION SITES

ONE ACRE OR MORE – Should a new development project with a valid State Stormwater Permit and WDID number become abandoned or inactive during the course of construction and at the discretion of the City’s Stormwater Inspector, the Stormwater inspection staff will initiate the following procedure.

1. Determine the stability of the construction site as it relates to storm water runoff and conformance with the approved SWPPP.
2. If the site is unstable and has the potential to adversely impact receiving water quality, the City will contact with the owner/developer by telephone, written letter, and/or electronic mail within 14 days of determining the project has been abandoned or inactive. Inform the owner of the current status and encourage them to stabilize the site according to the project's SWPPP.
3. Conduct Stormwater site inspection after 21 days of determining the project has been abandoned or inactive, or as applicable to determine if adequate BMP's were installed to establish stability, and monitor through the wet season by communicating with the owner/developer representative via periodic Stormwater inspections.
4. Should the owner/developer be unresponsive, uncooperative, or fails to install adequate BMP's as defined above, a City citation and/or RNOV will be issued. If the site is not properly addressed, then the Stormwater project file will be forwarded to the RWQCB staff for further processing and handling.

LESS THAN ONE ACRE – Should a new development project with a current encroachment permit or subdivision agreement from the City become abandoned or inactive at the discretion of the City's Stormwater Inspector, the City will initiate the following procedure.

1. Determine if the construction site is unstable and without proper stabilization and has a potential to impact water quality.
2. Attempt to make contact with the owner/developer by telephone, written letter, and/or electronic mail prior to the wet season, or as necessary.
3. Inform the owner/developer of the current status and encourage him/her to stabilize the site according to the approved plans and the City Standards before the first rain event.
4. Conduct Stormwater site inspection to determine if adequate BMP's were installed to establish stability and monitor through the wet season by communicating with the owner/developer representative.
5. Should the owner/developer be unresponsive, uncooperative, or fails to install adequate BMP's as defined above, a City citation and/or RNOV will be issued. If the site is not properly addressed, then the Stormwater project file will be forwarded to the City Attorney's Office for further processing and handling including bond recovery proceedings.

CITY REPORTING

By September 15th of each year, the City is required to submit an annual report to the RWQCB describing the City's stormwater management program's effectiveness in accordance with the State's General Permit for MS4's. In part, the report encompasses goal expectations for the construction element of the permit. As such, the Development Services Department, Engineering - Land Development Division will maintain permanent records of all active SWPPP's including inspection reports, and maintain for three years following each project NOT.

SECTION 4.0

BEST MANAGEMENT PRACTICES, GUIDELINES



This section of the Manual identifies some of the construction related BMP's that are available to contractors. This is not a complete list of BMP's that can be utilized, but is meant to be an overview. The section is divided into two subsections: Erosion and Sediment Control Practices, and Good Housekeeping Practices.

OVERVIEW

The purpose of this section of the Manual is to provide general guidance for implementing BMP's that will eliminate or reduce the discharge of pollutants from construction sites to waters of the State. Every construction site is unique, and therefore, the combination of BMP's implemented will be customized for each site. The information provided in the section concerning the selection and installation of construction BMP's is meant to give guidance to contractors to better understand the function of each BMP. This section does not include all of the products, systems and/or devices that are available to contractors today. This is only a sampling of the most common BMP's currently is being used by the construction industry in the State of California and in the City of Roseville.

4.1 EROSION & SEDIMENT CONTROL PRACTICES



Construction activities contribute to soil erosion and can result in sediment and pollutant transport to local waterways by stormwater runoff. Sediment transport from soil erosion can be effectively controlled or reduced by the use of preventive measures, BMP's (Best Management Practices). BMP's are employed in the following four preventive processes:

Scheduling – Schedule construction phases around the weather to better manage erosion and sediment control.

Erosion Control – Soil stabilization is a key component in the control of erosion. By stabilizing disturbed soil areas with covers or binders, the exposed soils are less likely to erode from the effects of wind or rain.

Storm Water Flow Diversion – Another key component in the control of erosion is the diversion of storm water flows around disturbed soil areas(DSA's) or the conveyance of flows through DSA's in a non-erosive manner.

Sediment Control – Finally, the last key component employs sediment control BMP's such as fiber rolls, silt fences, and drain inlet protection. Sediment BMP's offer limited protection in the event that erosion control or stormwater flow diversion BMP fails. Sediment control may incorporate the use of detention basins or if necessary, advanced water filtration systems.

4.1.1 Scheduling

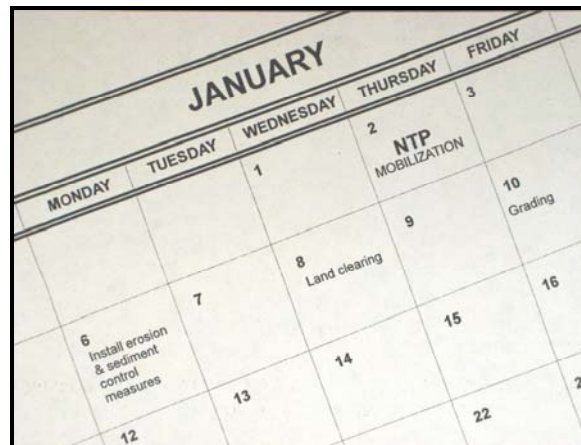

The project schedule should sequence construction activities with the installation of erosion and sediment control measures. The purpose is to reduce the amount and duration of soil exposed to erosion by wind, rain, and vehicle tracking. With this in mind, construction schedule planners need to consider the start of the wet season (City of Roseville defines wet season as 10/1 to 4/30) when developing the projects critical path items. Good project planning incorporates the following:

- Incorporate the use of a schedule or flow chart to layout the construction plan.
- Work out the sequencing and timetable for the starting and completion of each activity such as site clearing, grading, excavation, pouring foundations, installing utilities, etc.
- Avoid or minimize land disturbance activities scheduled between October 1 and April 30. Extra precautions should be implemented to protect the site from erosion during the wet season.
- Allow enough time before the rainfall begins to stabilize soil with vegetation or by physical means.
- Erosion may be caused during dry seasons by unseasonable rainfall, nuisance runoff, wind and vehicle tracking. Maintain site stabilization year-round, and keep wet season sediment trapping devices in an operational condition. The CGP requires minimum erosion and sediment control BMP's be in place regardless of the time of year. Check permit requirements.
- Whenever possible, schedule work to minimize the extent of site disturbance at any one time.
- Incorporate staged re-vegetation of graded slopes and installation of geotextile blankets as work progresses.
- Routinely verify that work is progressing in accordance with the project schedule. If progress deviates, take corrective actions.

4.1.2 Erosion Control



Soil stabilization is a key component in the control of erosion. By stabilizing disturbed soil areas with covers or binders, the exposed soils are less likely to erode from the effects of wind or rain. The following erosion control BMP's are commonly used.

- **Preservation of Existing Vegetation**
- **Straw Mulch**
- **Broadcast Seed**
- **Hydro seeding**
- **Hydraulic Mulch**
- **Soil Binders**
- **Wood Mulching**
- **Geotextiles, Plastic Covers, Blankets and Mats**

General information including: a description, common application, and maintenance requirements for each of these BMP's are provided in the following pages.

PRESERVATION OF EXISTING VEGETATION



Description

This BMP is designed to maintain areas of existing vegetation to reduce the amount of sediment in sheet flow runoff by maximizing existing site vegetation and minimizing the extent of the disturbed area.

Common Application

Used as buffer strips adjacent to wetlands and other sensitive areas. Also, helpful protection for the perimeter of project boundaries and property lines along with being utilized to protect undeveloped portions of a job site.

Maintenance

Areas of vegetation to be preserved need to be clearly marked on the Project's SWPPP site plans and fenced or flagged in the field. Traffic, parking, stockpiles and storage areas should be located away from vegetated areas. If additional vegetation is needed within the vegetated area, seeding will be required (see Hydro-seeding).

Fencing and signage for preserved trees shall be strictly observed. Failure to observe conditions of the Tree Permit is a violation of the Roseville Municipal Code, Zoning Ordinance (Chapter 19.74) and Tree Preservation Ordinance (Chapter 19.66).

STRAW MULCH (Broadcast Straw)



Description

Straw mulch consists of placing a uniform layer of straw and incorporating it into the soil with a studded roller or anchoring it with a tackifier. Straw mulch is used as a temporary surface cover for soil stabilization on disturbed soil areas until soils can be prepared for re-vegetation. It is also used in combination with temporary and/or permanent seeding strategies to enhance plant establishment.

Straw mulch must be evenly distributed on the soil surface. Proper application rates should be followed so that mulch covers the soil in a uniform layer without any visible bare spots.

Straw mulch may be spread with a straw blower or by hand. Blowing straw should only be performed when winds are nearly nonexistent, and measures shall be taken to ensure that air born dust is kept to a minimum. Manual application is time and labor intensive and tends to result in a less consistent thickness.

Common Application

All graded areas with smooth and hard surfaces; however it is practical and effective for smaller areas. All disturbed or non-vegetated areas, regardless of slope, within 50 feet of natural drainages shall be covered with straw, tacked in place, at a minimum.

Maintenance

Inspect straw mulch prior to and after rain events. Repair any damaged areas and re-mulch exposed areas of soil.

BROADCAST SEEDING



Description

This BMP consists of the application of vegetative seeds. As vegetation grows, and becomes established, it stabilizes graded areas preventing sediment transport and reducing erosion.

Common Application

All graded areas with smooth and hard surfaces.

Seed Specifications and Application

The City's Standards require that broadcast seed shall to be applied as follows: Brando Brome @ 12 pounds per acre and Rose Clover @ nine pounds per acre. Areas with sandy, dry soil shall receive: Zorro Annual Fescue @ six pounds per acre and Rose Clover @ nine pounds per acre. A fertilizer consisting of 16-20-0 shall be applied at a rate of 500 pounds per acre.

If hydro-seeding is used, seed quantities shall be increased by 30 percent.

Seed for creek banks, wetlands, etc., shall conform to the latest requirements from the California Department of Fish and Game. For more information visit: www.dfg.ca.gov

Maintenance

Inspect area regularly to ensure seed is germinating and vegetation is being established. Water as needed to ensure establishment. Inspect areas prior to and after rains events.

HYDRO-SEEDING



Description

Hydro-seeding typically consists of applying a mixture of fiber, seed, fertilizer and stabilizing emulsion with hydro-mulch equipment to temporarily protect exposed seeds and help establish rapid growth with plant greater density.

Common Application

When selecting a hydro-seed mixture, evaluate the site conditions with respect to:

- Soil conditions and soil type.
- Site topography – steep slopes are difficult to protect with temporary seeding.
- Season and climate – seeding during summer or in arid areas may limit germination and plant establishment.
- Water availability - early spring or fall is the ideal period in which to hydro-seed. Irrigation of hydro-seeded areas may be required.
- Sensitive adjacent areas - If seed is incompatible to adjacent sensitive vegetation care shall be taken to isolate the hydro-seeding operation.

Seed Specifications and Application

See broadcast seed section for seed mix. For hydro-seeding seed quantities shall be increased by 30 percent. Seed for creek banks, wetlands, etc., shall conform to the latest requirements from the California Department of Fish and Game. For more information visit: www.dfg.ca.gov

Maintenance

Inspect area regularly to ensure seed is germinating and vegetation is being established. Water as needed to ensure plant establishment. Inspect areas prior to and after rains. Repair any damaged ground cover and re-vegetate exposed soil areas.

HYDRAULIC MULCH



Description

This BMP is used to temporarily prevent soil and wind erosion. Hydraulic mulch is a mixture of shredded wood fiber, water and stabilizing emulsion or tackifier. Hydraulic mulch is applied to areas until permanent vegetation (landscaping, etc.) can be planted and established, or to areas that will be re-disturbed after periods of inactivity. Wood fiber mulches are mixed in a hydro-seeder and applied as liquid slurry. Material is applied from a spray gun on an elevated nozzle or from a hand directed hose.

Bonded fiber matrix (BFM) is an alternative soil stabilizer to hydraulic mulch. The bonded fiber matrix consists of a continuous layer of elongated wood fiber strands mixed with a bonding agent. This product is also applied as slurry, which once dried becomes a high strength, porous, erosion resistant mat.

As opposed to hydraulic mulch, hydraulic matrix consists of a wood fiber base layer and a paper fiber top layer mixed with a binding agent and applied as liquid slurry.

Common Application

All graded areas with smooth and hard surfaces requiring short-term erosion protection.

Maintenance

Inspect area regularly to ensure erosion is not occurring. Inspect areas prior to and after rain events. Repair any damaged areas. Care shall be taken not to over spray hydraulic mulch or hydraulic matrix into the vehicle traveled way, sidewalks or channels. Assure that covered areas remain undisturbed.

SOIL BINDERS



Description

This measure is the most temporary, least effective and most maintenance intense of the temporary soil stabilization measures. The material consists of a solution or emulsion of polymeric or lignin sulfonate soil stabilizers.

Soil binders are applied to disturbed soil areas which will be re-disturbed after periods of inactivity. A disadvantage of soil binders is that their integrity can be effectively compromised by construction activity. Depending upon the type soil binder used, the period of effectiveness is from three months to two years. Using this measure, the site should be evaluated with respect to soil types and surface materials, suitability of the situation and performance and longevity requirements.

In application, it is important for the binder to adhere to and penetrate the soil surface. The untreated surface should be scarified and contain sufficient moisture for the binder to achieve uniform penetration. Soil binders require a minimum curing time for full effectiveness and should not be applied during or immediately prior to rainfall.

Common Application

All graded areas with smooth and hard surfaces requiring short-term erosion protection. This BMP works best in non-traffic areas.

Maintenance

Inspect area regularly to ensure erosion is not occurring. Inspect areas prior to and after rain events. Repair any damaged areas. Areas of traffic should be inspected for the effect on the binder and destabilization of the soil surface. The binder shall be reapplied for acceptable stabilization.

When selecting a product, consider the chemical components and review the Material Safety Data Sheet(MSDS). The manufacture will be able to provide toxicity testing data, which needs be listed in the project SWPPP. If the product has a potential for becoming a pollutant, a different product will need to be used.

WOOD MULCHING



Description

This BMP consists of applying a mixture of shredded wood mulch, bark or compost to bare soil to reduce runoff, increase infiltration and reduce erosion due to rainfall impact. Wood mulch provides soil stabilization, primarily for landscaping projects. It is used as a temporary protection of disturbed soil areas during construction pending permanent vegetative cover, and as a permanent, non-vegetative ground cover for slopes.

Select wood mulch products appropriate for the application and site conditions. Prior to placement, consult with the City Planning Department to ensure the mulch is compatible with planned future projects. Application preparation involves removal of existing vegetation, filling and compaction of holes or voids and scarifying the embankment. Depending upon the product, wood mulch should be placed at a depth of two to three inches.

Common Application

All graded areas with smooth and hard surfaces requiring short-term erosion protection.

Maintenance

Inspection and maintenance involves monitoring to assure the mulch lasts an adequate time to achieve erosion control objectives. Inspect areas prior to and after rains events. Repair any damaged areas by adding more wood mulch.

GEO-TEXTILES, PLASTIC COVERS, BLANKETS & MATS



For installation details
see Appendix (A)
BMP – 1
BMP – 2

Description

These measures are utilized to protect soil from erosion by wind or rain in areas that are typically difficult to stabilize with other erosion control BMP's.

Common Application

Typically, used on slopes near disturbed soil areas where the slopes are steeper than 3:1, where erosion potential is high and in disturbed areas where plants are slow to develop. These BMP's are also used on stockpiles, slopes adjacent to water bodies and in drainage channels. They are normally used as an immediate measure when disturbed soil areas are particularly difficult to stabilize.

A product appropriate for the site conditions should be selected from the various mats and blankets available. When selecting a product, consideration should be given to the following:

- Effectiveness of reducing erosion, flow velocity and runoff
- Regulatory acceptability or environmental compatibility
- Compatibility with native plants, wildlife, moisture retention
- Durability, longevity and maintenance

When erosion control blankets and mats are used in open space and preserve areas, only blankets and mats made of biodegradable materials, including the netting, shall be used. Also, any products used should be considered "wildlife friendly", and not pose a potential for entrapment.

Site preparation is essential to ensure blankets and mats perform as intended.

Remove all rocks, clods, vegetation or other obstructions and grade to allow the blanket or mat to come into consistent contact with the soil surface. Improper installation allows rain runoff to flow under the blanket.

Maintenance

Blankets and mats should be inspected periodically, and after rainstorms for signs of erosion or undermining. Failures should be corrected immediately. Material should be reinstalled following any tears or separations, and the slope or channel should be backfilled and stabilized.

4.1.3 Stormwater Flow Diversion



Diverting stormwater runoff into areas that are designed to receive it and to transport it off site without causing erosion or sedimentation problems is helpful for most construction sites. By creating earth dikes to direct the runoff into constructed swales and ditches, areas where erosion and sediment control are a concern will be more stable. The following flow diversion BMP's are commonly used.

- **Earth Dikes, Drainage Swales and Ditches**
- **Slope Drains**

General information including: a description, common application, and maintenance requirements for each of these BMP's are provided in the following.

EARTH DIKES, DRAINAGE SWALES and DITCHES



For installation
detail see
Appendix (A)
BMP – 3

Description

These measures intercept, divert and convey surface runoff around or through the project in a non-erosive manner. They convey surface runoff down slopes or along paved surfaces to intercept runoff, along the top of slopes to divert surface flow from slopes and divert and direct runoff toward stabilized drainage systems below steep grades where runoff begins to concentrate.

Common Application

Velocity is an important factor, and should be considered in evaluating the potential effect of erosion. It may be necessary to use other water pollution control measures such as check dams, plastic sheeting or blankets to prevent scour and erosion in these swales, dikes and ditches. In some cases, the swale may need to be constructed of concrete or rock.

Care should be taken to correctly size and locate earth dikes, drainage swales and lined ditches. Excessively steep, unlined dikes, swales and ditches are subject to extreme erosion and gully formation.

Maintenance

These BMP's should be inspected before and after each rain event and during extended rain events of 24 hours or more. Check channels, embankments and ditch beds for erosion, washout and accumulation of sediment and debris. Remove sediment accumulation and debris and repair or replace lost riprap, linings or soil stabilization as needed.

SLOPE DRAINS



For installation
detail see
Appendix (A)
BMP – 4

Description

A slope drain conveys concentrated runoff down a slope into a stabilized, water-receiving area. Slope drains are used with lined ditches to convey surface flow away from slope areas to protect cut or fill slopes.

This type drain is normally a combination of an inlet pipe for convergence of water at the top of slope, a flared discharge for that pipe, and a continued conveyance of the water into a lined channel down the remainder of the slope. Severe erosion may result if a slope drain fails due to overflow or pipe separation. Pipe connections should be watertight.

Common Application

In general, limit the area which one-slope drain services to 10 acres. The maximum grade of the drain is generally 2:1. Install slope drains perpendicular to the slope contour. Compact the soil around and under the slope drain inlet, outlet, and along the length of the pipe. Protect the pipe inlet with filter fabric. Use flared end sections for inlets and discharges for pipes 12 inches in diameter and larger. Anchor the pipe to the ground.

Protect the discharge outlet with riprap or other velocity dissipation devices. For high velocity discharge, integrate concrete into the riprap.

Maintenance

Inspect prior to and after each rain event and twice monthly until the tributary drainage area is stabilized. Inspect outlets for erosion and downstream scour. In the event of scour, reduce the flows into the channel unless other preventative measures can be implemented.

4.1.4 Sediment Control



Sediment control BMP's are most effective when used in conjunction with erosion control BMP's. The combination of erosion control and sediment control is usually the most effective means to prevent sediment from leaving the project site and potentially entering storm drains and receiving waters. In most cases, a construction site will require an effective combination of both erosion control and sediment control BMP's be installed. The following sediment control BMP's are commonly used.

- **Fiber Rolls**
- **Silt Fence**
- **Straw Bale Barriers**
- **Drain Inlet Protection**
- **Stabilized Construction Entrance/Exit**
- **Gravel Bag Berm**
- **Sediment Trap**
- **Check Dam**
- **Street Cleaning**
- **Wind Erosion and Dust Control**
- **Sediment Basins**
- **Active Treatment Systems**

General information including: a description, common application, and maintenance requirements for each of these BMP's are provided in the following.

FIBER ROLLS (Wattles)



For installation
detail see
Appendix (A)
BMP – 5

Description

A fiber roll consists of straw, flax or synthetic fiber that is rolled and bound into a tubular cylinder and placed either at the bottom of a slope or across a slope. Often, rolls are placed across a slope in benches. These rolls intercept runoff; reduce the flow allowing sediment to settle out. This control is much easier to install and maintain than silt fencing, straw bale dikes, and sand bag dikes but may not be as effective.

When fiber rolls are used in open space and preserve areas, only waddles made of biodegradable materials, including the netting, shall be used. Also, any products used should be considered “wildlife friendly”, and not pose a potential for entrapment.

Common Application

Fiber rolls are placed at the top of slopes to intercept sheet flow from flatter areas, on the face of slopes, at the bottom of the slopes and perpendicular to the flow lines in ditches and swales. Across slopes, rolls should be placed on a level contour.

Rolls need be embedded into the soil at a depth of four inches and staked down at an interval of every four feet to be effective.

When used to create storm water benches on a slope, the vertical spacing of the rolls is determined by the slope grade.

Slope percentage	Sheet flow not to exceed
0 – 25%	20 feet
25 – 50%	15 feet
Over 50%	10 feet

Maintenance

Inspect fiber rolls prior to and after rain events, and at least daily during prolonged rainfall. Maintenance includes replacing slumping rolls, removing accumulated sediment and filling and compact any gullies that have formed.

SILT FENCE



For installation
detail see
Appendix (A)
BMP – 6

Description

A silt fence is a temporary linear barrier that captures sediment by retaining runoff allowing the sediment to settle out. Silt fences are normally used at the toe of slopes where soil has been disturbed and around soil stockpiles.

Common Application

The fence should be installed on a relatively level contour. The ends of the fence should be angled up stream to prevent sedimentary water from running around the ends.

Silt fences are inappropriate for use across intermittent or permanent streams, channels or any location where concentrated flows are anticipated.

Maintenance

Silt fences can be maintenance intensive. Perform inspections before and after every rain event and every 24 hours during extended rain events. Also, weekly inspections throughout the rainy season are recommended. Sediment deposits shall be removed when they reach 1/3 of the fabric height. All torn or decomposed fencing should be replaced.

STRAW BALE BARRIER



Description

This is a temporary linear sediment barrier. Its purpose is to intercept and slow storm water runoff. This barrier is effective in allowing sediment to settle prior to leaving the site. However this BMP is labor intensive, expensive and cumbersome both to install and to remove.

Common Application

The straw bale barrier is commonly used along the perimeter of the site, at the toe of slopes, around soil stockpiles and across swales or ditches. The barrier should be placed a minimum of 20 feet back from the toe of the slope to provide an area where silt can settle out.

The ends of the barrier should be angled up stream to prevent sediment laden water from running around the ends.

Straw bale barriers are inappropriate for use across intermittent or permanent streams, channels or at any location where concentrated flows are anticipated. They should not be used on paved surfaces, in lined ditches, or for drain inlet protection. Sand bag or gravel bag barriers are more practical for these applications.

Maintenance

Inspect straw bale barriers weekly and prior to and after rainfall events. Repair or replace broken or damaged bales as necessary. Remove accumulated sediment when it reaches one-third the barrier height. Repair washouts or other damage as needed. When the barrier is no longer needed, remove it and re-grade the area.

DRAIN INLET PROTECTION



For installation
detail see
Appendix (A)
BMP – 7
BMP – 8
BMP – 11

Description

Storm drain inlet protection reduces sediment, carried by runoff from a construction site, entering the storm drain system. Effective storm drain inlet protection allows sediment to settle out of water, or filters sediment from the water before it enters the drain inlet. Inlet protection is the last line of defense for water quality prior to water entering the system and being transported to a creek or stream.

Common Application

There are typically two common situations where drain inlet protection is needed. The first is where the storm drain system and drain inlets are in the process of being constructed, and the second is where the drain inlets are either existing or just completed.

For drain inlets under construction, the four common devices used are sandbag barriers, fiber roll barriers, filter fence barriers and filter bags. The sand bags are stacked (usually two high) around the drain inlet in a circle. A fiber roll can be used as a barrier around drain inlets and grated manholes. The filter fence is an effective drain inlet protection measure in open areas and where sheet flows are low and do not exceed 0.5 cubic feet per second. Filter bags are installed inside the inlet and must be used in combination with filter fences, sandbags or fiber roll barriers.

For existing drain inlets, a combination of filter bags and rock bags are used to settle out and trap sediment. A filter bag is placed and secured just under the grate. Rock bags are placed adjacent to the upstream side of the drain inlet, butted up against the curb face, and angled slightly toward the drain grate. The gravel bags used shall be of sufficient resiliency to withstand vehicle/construction traffic without tearing and depositing gravel in the catch basin or on the street. On heavier traveled roadways, rock bags may be omitted, as a matter of public safety, at the construction inspector's discretion.

Maintenance

Inspect drain inlet barriers before and after storms, at 24-hour intervals during extended storms, and weekly during the rainy season. Check to determine if sediment is by-passing the barrier during inspections. Drain inlet protection needs to be removed once the construction site is 70% vegetated and the permit has been terminated.

STABILIZED CONSTRUCTION EXIT/ENTRANCE



For installation
detail see
Appendix (A)
BMP – 9

Description

This BMP is used to prevent the tracking of soils and sediment off site. It entails the placement of aggregate at the exit/entrance for the construction site in order to reduce the tracking of mud and dirt into streets and public rights-of-ways.

Common Application

Usually, site conditions dictate the design and location of the construction entrance and/or exit. The site access points should be designed to support the heaviest equipment using them. When these access points are constructed, all site personnel should use them exclusively.

The aggregate access needs to be a minimum of 50 feet long and 10 feet wide. The aggregate should be angular, three to six inches in size and one foot in depth. Place the aggregate over a geo-textile fabric. Grade the construction exit/entrance to prevent runoff from leaving the site. Route all runoff from the exit/entrance through a sediment-trapping device prior to discharge.

Rattle plate structures are acceptable methods of stabilizing construction access points providing that they are equally or more effective than the aggregate type. , Rattle plate structures used in combination with aggregate stabilized construction accesses can improve the reduction of tracking.

Maintenance

Routinely check the exit/entrance for damage and effectiveness. Remove accumulated sediment and replace stabilization material as needed.

GRAVEL BAG BERM



Description

This BMP consists of a row of gravel bags installed end to end to form a barrier across a slope to intercept runoff, reduce runoff velocity and release runoff as sheet flow after settling out sediment.

Common Application

These berms are installed along the top, face and grade breaks of slopes. Proper installation is crucial to ensure effectiveness and performance. The berm should be installed level along the contour of a slope, and tightly butted together, but not overlapped.

Bags are usually manufactured of woven polypropylene, polyethylene, polyamide, or burlap fabric. The ideal size of a filled bag when laid horizontal is 1.5 feet long by one foot wide by three to four inches thick. Filling should be 1/2 inch to one inch of washed aggregate.

Although gravel bag berms settle out some settlement, they should not be substituted for linear settlement barriers such as fiber rolls or silt fence. Bag material is normally sensitive to ultraviolet light and limited in durability.

Maintenance

This BMP is labor and maintenance intensive. Inspect gravel bags prior to and following rain events and weekly during the rainy season. Repair and replace broken or ripped bags and remove accumulated sediment when it reaches 1/3 the height of the bag. Fill and compact washouts and gullies when necessary.

SEDIMENT TRAP



Description

The sediment trap is used as a pretreatment measure for entry of the runoff into the storm drain system or natural waterway. This BMP allows sediment to settle out of runoff prior to the discharge of the water into the local storm drainage system. A sediment trap typically is designed to treat runoff from a watershed not more than five acres.

Common Application

This is a temporary basin formed by shallow excavation, perimeter construction of an earthen embankment or an embankment constructed across a waterway or low drainage area. It includes a controlled release structure. The trap should be excavated where breach of the perimeter would not pose a risk to life or property. Access should be provided for maintenance, including sediment removal. The maximum area for this BMP to service is five acres.

The length of the trap should be more than three times the width. A professional civil engineer shall design traps with levees greater than five feet in height. The exact dimensions should be reflected on the SWPPP. The trap inlet should be located as far as possible from the outlet structure in order to allow maximum sediment settlement. Traps may require protective fencing to ensure safety.

Maintenance

Traps should be inspected before and after every rain event, weekly during the rainy season, and at 24-hour intervals during extended storms. Check inlet and outlet structures and spillways for signs of erosion, damage or obstructions. Examine trap banks for seepage and structural soundness. Remove accumulated sediment when the storage trap is 1/3 full.

To assist with the vector control, vegetation should be removed from the basin frequently. For more information concerning vector control visit www.placermosquito.org.

CHECK DAM



Description

This BMP is a small structure constructed of rock or gravel bags, placed across a natural or man-made drainage channel or ditch. Check dams reduce scour and channel erosion by reducing flow velocity and encouraging sediment settlement.

Common Application

These dams are generally placed in:

- Small open channels which drain 10 acres or less
- Steep channels where runoff velocities exceed five feet per second
- Ditches or channels where grass linings are being established
- Temporary ditches where short term service does not warrant establishment of erosion resistant linings
- In combination with other BMP's such as sediment basins and traps

Install check dams 20 feet from the outfall structure and at regular intervals along the channel, based on erosion characteristics and the grade percentage of the drainage swale. Place dams closer together where there is a high potential of erosion.

The dams should be placed at a height and distance allowing small pools to form behind them, but also allowing high velocity runoff (typically a two year storm or larger) to safely flow over them without an increase in upstream flooding or damage to the dam. Check dams should be constructed to pond runoff flows so the backwater from the downstream dam reaches the toe of the upstream dam. Check dams are not appropriate in channels that drain areas greater than ten acres.

Maintenance

Check dams require extensive maintenance after storms or high velocity flows to repair damage. Remove all sediment when it reaches 1/3 the dam height.

STREET CLEANING



Description

This BMP is used to remove dirt, mud, rock, sand or other foreign materials tracked onto public streets and paved areas.

Common Application

Streets will need to be cleaned immediately following the discovery that tracking has occurred. In addition, City inspection staff may require daily sweeping. Also, streets need to be cleaned with a power broom or a hand broom and should not be washed with water without the approval of a Stormwater Inspector or Construction Inspector.

The site manager is responsible for cleaning construction vehicles leaving the site on a daily basis to prevent dust, silt, mud and dirt from being released or tracked off site.

Adjacent street frontages should be swept at least once a day to remove silt and other dirt evident from construction activities.

Maintenance

Failure to keep the streets clean shall be considered a violation of the City of Roseville's Urban Stormwater Quality Management Ordinance and the Regional Water Quality Control Board General NPDES Permit for Construction Activities. Also, the City may clean the areas and bill the Contractor. Any mud displaced into the City storm drain system by the Contractor shall be removed at the discretion of City inspection staff.

WIND EROSION or DUST CONTROL



Description

This BMP is used to reduce or eliminate fugitive dust emissions. Fugitive dust is particulate matter discharged into the atmosphere due to man-made activity or conditions. Examples of dust sources include excavating and trenching, drilling, boring, earthmoving and grading operations, pavement or masonry cutting operations, brush clearing, travel on unpaved roads within construction sites, and wind-blown dust from uncovered graded areas and storage piles. Wind erosion or dust control consists of applying water or commercial stabilizers to prevent or minimize generation of dust.

Although the City of Roseville enforces its own dust control standards, the Placer County Air Pollution Control District (District) is the leading agency enforcing fugitive dust and air quality control requirements in Roseville as well as the rest of Placer County. Placer County general air quality notes are stated on all development plans issued by the City of Roseville. Those general notes can also be found on the following link: www.roseville.ca.us/pw/engineering/land_development/standard_notes.asp

A copy of Rule 228 may be obtained by contacting the Placer County Air Pollution Control District at (530) 889-7930, or by downloading the rule from the District web page www.placer.ca.gov/Departments/Air/airquality.aspx

The District adopted a major amendment to District rule 228 on April 10, 2003, a rule that previously addressed fugitive dust only in the Lake Tahoe area. Rule 228, Fugitive Dust, is applicable to the entire County of Placer and addresses fugitive dust generated by construction and grading activities, as well as by other land use practices including recreational uses.

The rule establishes standards to be met by activities generating fugitive dust. Among these standards to be met is a prohibition on visible dust crossing the property boundary, generating high levels of visible dust (dust sufficient to obscure vision by 40%), and an increase in monitoring dust concentrations of 50 micrograms per cubic meter. Also, there are controls on the track-out of dirt and mud onto public roads. The regulation also establishes minimum dust mitigation and control requirements.

Common Application

For the best results, dust control should be applied conforming to Caltrans standard practices. Water or environmentally safe soil stabilizer should be sprayed on all exposed earth surfaces during clearing, grading, earth moving and other site preparation. Dry disturbed areas and dry stockpiles of soil shall be watered throughout the day to minimize dust. Cover small stockpiles or small disturbed areas as an alternative to water or stabilizer. Trucks transporting dry soil shall be covered with tarpaulins. Care should be taken when applying water and stabilizer to prevent washing sediment off-site or into storm drains or natural waterways.

Grading activities need to be restricted or halted when winds exceed 15 miles per hour as deemed necessary by the Construction Inspector.

Maintenance

Do not apply so much water that you create a discharge. When applying commercial stabilizers, follow manufacturer's recommendations. The Contractor shall obtain a hydrant permit from the Environmental Utilities Department prior to the use of any City hydrant. For hydrant permit information call the City at (916) 774-5750.

SEDIMENT BASINS



Description

A sediment basin is a temporary basin formed by excavation or by constructing an embankment so that sediment-laden runoff is temporarily detained, allowing sediment to settle out before the runoff is discharged. A sediment basin is a controlled stormwater release structure formed by excavation or by construction of an embankment of compacted soil across a drainage way, or other suitable location. It is intended to trap sediment before it leaves the construction site. The basin is a temporary measure with a design life of 12 to 28 months in most cases. The main difference between a sediment basin and a sediment trap is that a basin is typically a much larger structure treating runoff from watersheds between 5 acres and 75 acres.

Common Application

Sediment basins are suitable for nearly all types of construction projects. Whenever possible, construct the sediment basins before clearing and grading work begins. Basins should be located at the stormwater outlet from the site but not in any natural or undisturbed stream. A typical application would include temporary dikes, pipes, and/or channels to divert runoff to the basin inlet.

Sediment basins should be considered for use:

- Where sediment-laden water may enter the drainage system or watercourses.
- On construction projects with disturbed areas during the rainy season.
- At the outlet of disturbed watersheds between 5 acres and 75 acres.
- At the outlet of large disturbed watersheds, as necessary.
- Where post construction detention basins are required.
- In association with dikes, temporary channels, and pipes used to convey runoff from disturbed areas.

Sediment basins must be installed only within the property limits and where failure of the structure will not result in loss of life, damage to homes or buildings, or interruption of use or service of public roads or utilities. In addition, sediment basins are attractive to children and can be very dangerous. Local ordinances regarding health and safety must be adhered to. If fencing of the basin is required, the type of fence and its location should be shown in the SWPPP and in the construction specifications. Bank slope ratios shall also be considered for emergency egress and safety.

Many development projects will be required to provide a stormwater detention basin for post-construction flood control and/or stormwater pollution control. A temporary sediment basin may be constructed by rough grading the post-construction control basins early in the project. Sediment basins are expected to trap 70-80 % of the sediment that flows into them if designed correctly. Basins can be designed to work in conjunction with erosion control practices such as temporary seeding, mulching, diversion dikes, etc., to reduce the amount of sediment flowing into the basin. For specifications on sediment basin designs, see the California Stormwater Quality Association BMP Handbook for Construction available at the following website:

www.cabmphandbooks.com

Maintenance

Sediment basins should be inspected before and after every rain event, weekly during the rainy season, and at 24-hour intervals during extended storms. Check inlet and outlet structures and spillways for signs of erosion, damage or obstructions. Examine basin banks for seepage and structural soundness. Remove accumulated sediment when the storage trap is 1/2 full.

Standing water should not be allowed in the basins for more than 72 hours. If water is present after 72 hours dewatering activities should be initiated. Contact the site inspector prior to any dewatering activities.

To assist with the vector control, vegetation should be removed from the basin frequently. For more information concerning vector control visit:

www.placermosquito.org

ACTIVE TREATMENT SYSTEM (ATS)



Description

This BMP involves the use of an on site chemical system to treat stormwater discharges from the construction site. The primary treatment process in an ATS is coagulation/flocculation. These systems can be very effective in reducing the sediment in stormwater runoff; however, extreme care must be used with these treatment systems. The chemicals used to enhance sedimentation may pose a potential hazard to water quality if handled improperly. In addition, these systems can be quite costly to set up and operate.

Common Application

ATS are used in conjunction with on-site detention basins when construction progress must remain active during the rainy season, or when a construction site's stormwater detention basin reaches, or will exceed capacity. Additionally, it may be appropriate to use an ATS when site constraints inhibit the ability to construct a correctly sized sediment basin, when clay and/or highly erosive soils are present, and/or when the site has significant contours.

Dischargers choosing to implement an ATS on their site shall comply with all of the requirements in Attachment F of the CGP, Order No. 2009-0009-DWQ. Noted below represents only a portion of those requirements. Review Attachment F for complete details.

The discharger shall maintain a paper copy of each ATS specification onsite in compliance with the record retention requirements in the Special Provisions of the CGP.

The ATS shall be designed and approved by a Certified Professional in Erosion and Sediment Control(CPESC), a Certified Professional in Stormwater Quality(CPSWQ), a California registered civil engineer; or any other California registered engineer.

The discharger shall ensure that the ATS is designed in a manner to preclude the accidental discharge of settled floc during floc pumping or related operations.

The discharger shall design outlets to dissipate energy from concentrated flows.

The discharger shall install and operate an ATS by assigning a lead person (or project manager) who has either a minimum of five years construction storm water experience or who is a licensed contractor specifically holding a California Class A Contractors license.

The discharger shall prepare an ATS Plan that combines the site-specific data and treatment system information required to safely and efficiently operate an ATS. The ATS Plan shall be electronically submitted to the State Water Board at least 14 days prior to the planned operation of the ATS and a paper copy shall be available onsite during ATS operation. At a minimum, the ATS Plan shall include:

- ATS Operation and Maintenance Manual for All Equipment.
- ATS Monitoring, Sampling & Reporting Plan, including Quality Assurance/Quality Control (QA/QC).
- ATS Health and Safety Plan.
- ATS Spill Prevention Plan.

The ATS shall be designed to capture and treat (within a 72-hour period) a volume equivalent to the runoff from a 10-year, 24-hour storm event using a watershed runoff coefficient of 1.0.

The discharger shall utilize a residual chemical test method that has a method detection limit (MDL) of 10% or less than the maximum allowable threshold concentration (MATC) for the specific coagulant in use and for the most sensitive species of the chemical used.

The discharger shall utilize a residual chemical test method that produces a result within one hour of sampling.

The discharger shall have a California State certified laboratory validate the selected residual chemical test. Specifically the lab will review the test protocol, test parameters, and the detection limit of the coagulant. The discharger shall electronically submit this documentation as part of the ATS Plan.

If the discharger cannot utilize a residual chemical test method that meets the requirements above, the discharger shall operate the ATS in Batch Treatment mode, and perform toxicity testing in accordance the requirements listed in Attachment F

The discharger shall electronically report all acute toxicity testing.

The ATS shall include a filtration step between the coagulant treatment train and the effluent discharge. This is commonly provided by sand, bag, or cartridge filters, which are sized to capture suspended material that might pass through the clarifier tanks.

Handling and disposal of all solids generated during ATS operations shall be done in accordance with all local, state, and federal laws and regulations.

The ATS shall be equipped with instrumentation that automatically measures and records effluent water quality data and flow rate. The minimum data recorded shall be consistent with the Monitoring and Reporting requirements below, and shall include: Influent Turbidity, Effluent Turbidity, Influent pH, Effluent pH, Residual Chemical, Effluent Flow rate, and Effluent Flow volume. Systems shall be equipped with a data recording system, such as data loggers or webserver-based systems, which records each measurement on a frequency no longer than once every 15 minutes.

Cumulative flow volume shall be recorded daily. The data recording system shall have the capacity to record a minimum of seven days continuous data. Instrumentation systems shall be interfaced with system control to provide auto shutoff or recirculation in the event that effluent measurements exceed turbidity or pH.

The system shall also assure that upon system upset, power failure, or other catastrophic event, the ATS will default to a recirculation mode or safe shut down.

ATS effluent shall comply with all provisions and prohibitions in the CGP, specifically the NEL's.

Turbidity of all ATS discharges shall be less than 10 NTU for daily flow weighted average of all samples and 20 NTU for any single sample.

Residual Chemical shall be < 10% of MATC7 for the most sensitive species of the chemical used.

If an analytical effluent sampling result is outside the range of pH NEL's (i.e., is below the lower NEL for pH or exceeds the upper NEL for pH) or exceeds the turbidity NEL (500 NTU's), the discharger is in violation of this General Permit and shall electronically file the results in violation within 24-hours of obtaining the results.

Each Project shall have a site-specific Operation and Maintenance (O&M) Manual covering the procedures required to install, operate and maintain the ATS.

Operators shall have training specific to using an ATS and liquid coagulants for storm water discharges in California. The training shall be in the form of a formal class with a certificate and requirements for testing and certificate renewal. Training shall include a minimum of eight hours classroom and 32 hours field training.

Any discharger who deploys an ATS on their site shall conduct the daily visual monitoring and record findings in the project data log. The log shall include the name and phone number of the person responsible for system operation and monitoring and their training.

A discharger operating in batch treatment mode shall perform toxicity testing in accordance with Attachment F of the CGP.

Maintenance

Daily on-site visual monitoring of the ATS operation and performance shall be done by a qualified person as required. The name and phone number of the qualified person assigned the responsibility of operation and monitoring of the system, and documentation of the qualified person's training as required by the statewide General Construction Stormwater Permit will need to be provided to the City of Roseville.

Active Treatment Systems require continuous monitoring when operating. Special attention needs to be given to ATS's whenever they are being started up for the first time, restarted after an extended down time, and after maintenance or repair work has been done on the system.

4.2 GOOD HOUSEKEEPING



Good Housekeeping on a construction site involves many aspects of construction activities and proper management. General Contractors, and their representatives, are responsible for keeping their site clean and managing their subcontractor's activities so that polluted water does not leave the site.

Construction activities can result in the transportation of pollutants to local waterways from non-storm water discharges. This section of the manual provides Best Management Practices for addressing non-stormwater discharges from construction sites. The following topics will be discussed in this section:

Disposal of Construction Waste – Construction sites generate a large amount of waste. Items such as trash, dirty water and material waste can accumulate on a site very quickly if not taken care of on a daily basis.

Process Discharge Containment – Many construction activities require the addition of water in their processes. Things such as boring and saw-cutting often require water injection. The water that is discharged during these activities is polluted and needs to be handled properly.

Stream Treatment – Construction work sometimes requires activities to take place near or in a stream bed. Extra care must be taken during these types of activities.

General Site Management – Good site management touches every aspect of a construction site. If a site is not consistently well managed, the potential of polluted water leaving the site is increased.

4.2.1 Disposal of Construction Materials



Concrete, stucco, mortars, Portland cement products, lime/fly ash treatment, gypsum and dry-wall materials are toxic to fish and the aquatic environment and require proper handling and disposal to minimize or eliminate discharges to gutters, storm drains, and watercourses. Concrete washout water, even though void of concrete sediment, typically contains heavy metals and high levels of pH, which are highly toxic to fish and aquatic life. Materials need to be covered and contained to protect them from rainfall and prevent toxic runoff.

- **Concrete Finishing, Mortar and Masonry Work**
- **Concrete Washout Area**
- **Stucco Work and Painting**
- **Lime/Fly Ash and Cement Treating**

General information including a description and control measures for each of these construction activities are provided in the following.

CONCRETE FINISHING, MORTAR & MASONRY WORK



Description

Following proper procedures in performing concrete finishing methods will minimize the impact of potential pollutants in runoff.

Mortar and masonry work requires many of the same protective measures as concrete work. It is not acceptable to wash out mixers, buckets, mortar boxes, or tools directly onto bare ground. Measures must be taken to contain washout and rinse water for treatment and proper disposal. Never perform concrete, mortar or masonry work during or just before rain events.

Control Measures

If dewatering is required, obtain the City Stormwater Inspector's approval for the disposal method. Disposal method will need to comply with applicable permits.

Protect all inlets that may be affected by any concrete finishing, or masonry work. Vacuum up or direct any water to collection areas for treatment or other disposal means.

Inspect containment structures prior to and during use and prior to rainfall. If repairs are required, ensure these are done in a timely manner and especially before a rain event. After use or at the end of a shift, ensure containment structures and the general work area are clean and that the wastes are disposed of properly.

CONCRETE WASHOUT AREA



For installation
detail see
Appendix (A)
BMP – 10

Description

Contact of concrete washout waste with stormwater is unnecessary and prohibited. Applications for this BMP include locations where concrete is placed wet and finished, and subsequently, where the concrete truck chute and equipment must be washed.

Concrete washout water, even though void of concrete sediment, typically contains a high pH level and heavy metals, which is highly toxic to fish and aquatic life. Never dispose of washout water into the street, storm drains, drainage ditches, watercourses, or by infiltration into the ground. If disposal by evaporation is impractical, then treatment, (Usually performed by a concrete washout service) of the water may be necessary to bring the pH down and remove any heavy metals. Measures need to be taken to keep wet and dry residue away from waterways and storm drains.

Control Measures

Two possible methods for washout management include concrete washout services or concrete providers with recycle systems built into their trucks. For an alternative to these two methods, a construction manager may build his/her own concrete washout basin from straw bales and plastic sheeting (see BMP – 10 installation detail in Appendix A).

Washout basins for concrete trucks should be placed in designated areas only. Locate this BMP 50 feet from any storm drain, natural water way or drainage ditch. Keep washout areas away from construction traffic. A sign should be erected clearly marking the washout location. Further signage may be necessary to direct concrete trucks to the designated area.

STUCCO WORK & PAINTING



Description

Stucco work and painting are activities that include the use of hazardous materials. These materials are toxic to fish and the aquatic environment and require proper handling and disposal to minimize or eliminate discharges to gutters, storm drains, and watercourses. Extra care with these types of wastes must be required on every construction site.

Control Measures

All materials should be placed, during work activity on plastic sheets large enough to contain drips and spills. Provide secondary containment in paint mixing and cleanup areas. After work has completed, sheets should be rolled in on themselves and placed in a waste receptacle designated to receive this type of waste. All leftover paint needs to be removed from the site, or disposed of in a paint washout bin designed to contain paint. There are services available that supply these specialized paint washout bins and retrieve them when full.

Never allow paint and/or stucco to be washed into a gutter, on the ground or into a storm drain inlet.

LIME/FLY ASH & CEMENT TREATING



Description

On a case-by-case basis, lime/fly ash or cement treated sub-base may be an acceptable substitute for placement of compacted aggregate base material. Prior to plan approval, the Developer shall submit to the City Engineer for review and approval, a proposal for lime/fly ash or cement treatment sections and compaction procedures, accompanied by recommendations from a California licensed, geotechnical engineer.

Control Measures

Prior to the start of treatment work, a plan shall be submitted to the Stormwater Inspector that addresses the issues of runoff containment, sampling and analysis, treatment, and release. If the treatment work is part of a project that requires a site specific SWPPP, then the above mentioned plan shall be added to the project's SWPPP. The amendment addressing lime/fly ash or cement treated sub-base shall be added to the on-site SWPPP before the activity takes place.

4.2.2 Process Discharge Containment



Utilizing the City's drainage system for residual discharge from boring equipment, saw-cutting or grinding operations without the required measures is prohibited. This type of polluted water, if allowed to enter into protected creeks and stream, is a violation of the Clean Water Act. Discharges from construction activities will need to be contained, pumped or vacuumed into tanks or barrels, removed from the site and properly disposed of. The intention of this section is to address all site water, which is discharged by mechanical means.

- **Boring Operations and Concrete Saw-Cutting**
- **Paving and Grinding Operations**
- **Dewatering Operations**

General information including a description and control measures for each of these construction activities are provided in the following.

BORING OPERATIONS & CONCRETE SAW – CUTTING



Description

All street boring and saw cutting operations shall include adequate measures to mitigate dirty water discharge. In no case shall the residual be allowed to enter the storm drain system.

Control Measures

An acceptable measure is pumping the discharge fluid into a tanker and hauling it away. Other measures proposed by the contractor will be considered by the City. Residual from concrete and asphalt concrete saw-cutting operations shall be removed with a commercial vacuum or pumped. The down stream drain inlets shall always be protected during these types of operations.

PAVING & GRINDING OPERATIONS



Description

This involves the handling of materials and wastes for (and the use of equipment associated with) pavement preparation, paving, surfacing, resurfacing, paint striping, thermoplastic striping and placement and the removal of all the above.

Control Measures

Grindings and wastes from removal of pavement and related materials need to be removed as the work progresses. Temporary waste stock piles should not be located in the flood plain, and need to be covered with plastic sheeting until removed from the site.

AC placement and removal equipment needs to be cleaned off-site. When storing equipment on site, the proper disposal of hardened residual is required. Do not allow residual from AC or PCC into the storm drain system or natural waterways.

Do not apply seal coat, tack coat, slurry seal or fog seal if rain is eminent during the application or curing period. Do not apply these surfaces during rain.

Prior to operation, verify that shut-off valves are operable on painting and thermoplastic applying equipment. When filling the thermoplastic pre-heater make sure there is a six inch space at the top of the container to prevent spills. Clean truck beds daily and recycle thermoplastic material when possible.

Do not transfer or load bituminous materials near storm drains or natural waterways. Verify all pressure is released prior to filling melting tank. Leave a six inch space at the top of the container to prevent spills.

For overlay work, gutters will need to be swept and left clean. Also for new paving work, storm drain inlets shall be protected.

DEWATERING OPERATIONS



Description

Dewatering sources may include groundwater accumulation, flushing of water mains, water from diversions, and water from rain events. Effluent discharged from the site is subject to the requirements of the General Construction NPDES permit.

Control Measures

If water has an odor, discoloration other than sediment, or an oily sheen or foam on the surface contact a stormwater quality professional for assistance.

Discharge to the storm drain system should be avoided. Other options include: (a.) retaining water on the site for construction use or allowing evaporation or percolation, (b.) discharging to the sanitary sewer with the written permission of the Environmental Utilities Department (last resort), (c.) discharging to adjacent property with written permission of the land owner or (d.) transporting, treating properly, and disposing of the effluent off the site. The above operations may be subject to the requirements of the NPDES permit. In some cases, the use of a gravity bag filters may be allowed by the City.

If the effluent is not obviously clear, it must be treated to remove sediment prior to discharge. Available portable water treatment equipment includes: sand media filters, pressurized bag filters, and cartridge filters. These filtering systems are usually trailer mounted, and can be rented for the day, week, or month. All records related to the dewatering operation must be monitored and recorded within the project SWPPP and provided to the RWQCB upon request. Regional dewatering permits normally require the contractor to monitor (test) the dewatering effluent, to maintain monitoring reports and to submit data to the RWQCB.

Extra care must be taken when flushing water lines that have been chlorinated. Water must be tested for chlorine content, and verified that it contains none, before it can be discharged to the drain system.

4.2.3 Stream Protection



Sometimes construction activities occur in the proximity of a stream or creek. These situations often require that additional BMP's be installed to protect the stream or creek from erosion and/or sediment issues that may potentially impact these watercourses.

Construction activities in or near a stream or creek may require permits from multiple agencies. Required permits may include RWQCB 401 Certification, U.S. Army Corps of Engineers 404 Permit and/or a Department of Fish and Game 1601 Agreement. Also, water sampling/testing will most likely be required prior to and possibly during construction work. Other City requirements when working adjacent to streams, creeks, or open space areas include:

- **Delineate sensitive areas or features (e.g. oak trees) with protective orange fencing and appropriate warning signs.**
- **Minimize construction access and impacts.**

General information including a description and control measures for each of these construction activities are provided in the following.

- **Temporary Stream Crossing**
- **Stream Bank Stabilization**

TEMPORARY STREAM CROSSING



Description

This is a structure placed across a waterway that allows construction traffic to cross without contacting the water. Culvert, ford and bridge crossings are typical. These crossings prevent stream bed erosion and downstream sediment due to construction traffic.

Control Measures

For a bridge or culvert, verify that the structure design has been prepared under the direction and approval of a registered civil or structural engineer. The structure shall not constrict waterway flow such that backups or washouts occur during rain events. Culverts are acceptable for perennial or intermittent streams and can accommodate heavy equipment loads. Fords are the least expensive, but are only acceptable for dry washes/ephemeral streams during the dry season. Bridges are the most expensive, but are appropriate for high velocity/steep gradient streams or where restrictions in the waterway channel are allowed.

Construct crossings during the dry season. Stabilize adjacent construction roadways, work areas, streambeds to prevent erosion. Minimize disturbance or removal of adjacent vegetation. Vehicles shall not be operated, stored, fueled or maintained in the wet or dry portions of the waterway without authorization of the resident engineer or as authorized by the Fish and Game Permit. Drip pans must be placed under vehicles/equipment on temporary stream crossing structures that remain idle from more than an hour. Being in such proximity to a water course, this measure and others implemented with it shall be installed correctly and maintained to prevent any polluting discharge. Any incident of discharge requires notifying the State RWQCB of the noncompliance.

Inspect temporary stream crossings weekly and after significant rain events for water flow blockage, sediment buildup, trapped debris, structural damage, riprap displacement or stream bed erosion. Verify sediment buildup is removed regularly and that riprap is replaced as needed to prevent erosion and maintain stability of adjacent areas.

Once the crossing is no longer needed, it will need to be removed carefully, and banks and bottom restored to original condition.

STREAM BANK STABILIZATION



Description

Proper planning and procedures for work in and around streams and channels can reduce the potential for discharge of sediment and other pollutants, and minimize the impacts of construction activities on watercourses and habitats.

Control Measures

Planning should consider scheduling, avoidance of in-stream construction, minimizing disturbance area and construction time, using pre-disturbed areas, selecting crossing location(s) and selecting equipment.

Preservation of existing vegetation in a stream bank provides water quality protection, stream bank stabilization and riparian habitat. Hydraulic mulch, hydroseeding, soil binders, straw mulch, or a combination thereof may be used on disturbed stream banks to provide temporary soil stabilization. Be sure to review the limitations of each so that the selection of the most appropriate for the application may be made. Also consider possible use of other soil stabilization and sediment control BMP's provided the application is appropriate and the limitations do not apply.

The primary goal while working near a stream is minimizing turbidity. There are three general ways to achieve this: construct a water diversion away from the work area, implement a barrier around the work area and/or minimize sediment suspension (erosion control) around the site.

Inspect BMP's and equipment daily and ensure necessary repairs for both are completed in a timely manner. If a piece of equipment leaks, remove it from the stream area immediately for repairs.

4.2.4 Site Management



Overall good site management can make a significant difference on the impact a construction site will have on water quality. This section will touch on a variety of elements commonly found at most construction sites. General site management includes, but is not limited to, the following items.

- **Water Conservation**
- **Liquid Pollutant Management**
- **Sanitary Septic Waste Management**
- **Vehicle & Equipment – Cleaning, Fueling, and Maintenance**
- **Hazardous Waste Management**
- **Contaminated Soil, Fertilizers and Pesticides**
- **Solid Waste Management**
- **Stockpile Management**
- **Material Use, Delivery and Storage**
- **Spill Prevention and Control**

General information including a description and control measures for each of these construction activities are provided in the following.

WATER CONSERVATION



Description

Water conservation involves practices that reduce the amount of water consumed for a given activity. There is less chance of erosion and transport of silt and pollutants off the site when water usage is properly managed. This would include activities such as watering the site for dust control and irrigation that can cause nuisance runoff.

Control Measures

Paved areas should be swept and vacuumed rather than washed. Always protect storm drain inlets or natural waterways from sediment and pollutants generated by watering activities. When possible, direct non-polluted runoff into areas onsite where it can be percolate into the ground. Water equipment should be kept in good working order. Always repair leaky watering equipment promptly.

LIQUID POLLUTANT MANAGEMENT



Description

Liquid Pollutants are prohibited from entering the storm drain system, natural waterways or drainage system, specifically, the wastes from drilling slurries and fluids, dredging and other non-storm water liquid discharges, which are not covered by separate permits. This section does not apply to the following: dewatering operations, solid wastes, hazardous wastes, concrete slurries, and liquid wastes covered by specific laws or permits.

Control Measures

Capture all liquid wastes that have the potential to impact water entering the storm drain system. Use temporary dikes or berms to direct surface flow of liquid wastes to a containment structure or device. The containment area should be controlled, that is, structurally sound, leak free, providing sufficient storage for anticipated volume. Appropriate structures include holding pits, sediment basins, roll off bins and portable tanks. Locate the containment structure as far as possible from storm drains, natural waterways and drainage channels.

Some liquid wastes may require testing and certification that they are non-hazardous before an appropriate disposal method is selected. Also, frequently inspect liquid waste containment areas and capturing devices for damage, and repair as needed.

SANITARY SEPTIC WASTE MANAGEMENT



Description

Measures must be taken to keep waste from portable toilets out of the storm drain system, natural waterways or channels. Also, discharges to the City's sanitary sewer system are not allowed from portable toilets.

Control Measures

Temporary sanitary facilities need to be located behind sidewalks, and at a minimum, 50 feet from a storm drain inlets, natural waterways, or channels. If high wind is predominant at the particular location, the toilet unit should be anchored to the ground.

Wastewater shall not be discharged, dumped or buried on private or public property. The general contractor's site manager shall monitor weekly any sanitary/septic waste storage and disposal procedures. The contractor's site manager is responsible for ensuring that the sanitary/septic facilities are maintained in good working order and wastes are transported offsite by a licensed septic service provider.

VEHICLE & EQUIPMENT - CLEANING, FUELING, and MAINTENANCE



Description

Wash water from vehicle and equipment cleaning shall not be discharged from the construction site because of the pollutants contained in it. All vehicles should be washed and cleaned offsite when possible. Also, fueling and maintenance work on vehicles and equipment onsite shall be closely monitored and controlled.

Control Measures

If it is necessary to clean a vehicle, or piece of equipment onsite, the construction site manager shall be notified, and the residue shall be contained and hauled offsite to an approved disposal location.

Spilled fuel shall be prevented from entering the storm drain system, natural waterways or ditches. Fueling areas should be on a level surface, and at a minimum, 50 feet away from any storm drain inlet, natural waterway or ditch. The area needs to be enclosed by a berm or dike which completely prohibits escape of pollutants in case of a spill.

Absorbent spill clean-up materials need to be available in fueling areas, used on all spills including small ones, and disposed of properly. If vehicles or equipment must be fueled in an area outside the designated area, a drip pan or absorbent pad should be used under the vehicle. Fueling operations can not be left unattended, and tanks should not be topped off. Fueling nozzles need to have automatic shut-offs valves. Vapor recovery nozzles should be used where required.

Designated maintenance areas need to be located, at a minimum, 50 feet downstream from any storm drain inlet, natural waterway, ditch or channel. For long duration projects, erection of a tent over the maintenance area is recommended.

For maintenance involving fluids, drip pans or absorbent pads need to be used below the vehicle or equipment. All spills should be cleaned up immediately, and absorbent materials need to be kept within the maintenance area. All used absorbents will need to be disposed of properly.

HAZARDOUS WASTE MANAGEMENT



Description

Hazardous waste shall be collected, stored and disposed of preventing contact with stormwater. Hazardous waste includes, but is not limited to the following substances: petroleum products, concrete curing compounds, septic wastes, paints, stains, wood preservatives, asphalt products, pesticides, acids, solvents and roofing tar. If non-hazardous waste comes into contact with the above wastes, it is considered hazardous.

Control Measures

Use containment berms in fueling areas. Provide secondary containment in paint mixing and cleanup areas. Place hazardous waste collection containers at convenient locations.

Adequate waste storage volume should be provided and located as far away as possible from storm drains, natural waterways, and drainage channels (50 feet at a minimum). Temporary containment should be impervious to spilled wastes. Supply equipment storage areas with appropriate spill cleanup materials.

Store hazardous waste in appropriate sealed containers which are clearly labeled with the contents and starting date of the accumulation. Do not store different wastes in the same container. Do not store incompatible materials in the same temporary containment facility. Prior to rain events, cover the containment area.

Hazardous waste shall be transported from the site by a licensed hazardous waste transporter and disposed of at an authorized, licensed disposal or recycling facility within 90 days of being accumulated. Properly dispose of rain water removed from temporary containment areas that may have mixed with hazardous waste.

The contractor and subcontractors need to be educated regarding identification, storage, and disposal of hazardous waste. Ongoing hazardous waste training should be included in regular safety meetings.

Ensure hazardous waste storage areas are inspected in conformance with contract provisions. Repair and replace perimeter controls, containment structures, covers and liners as needed.

CONTAMINATED SOIL, FERTILIZERS & PESTICIDES



Description

Contaminated soil is prohibited from entering storm drains, natural waterways or drainage channels. Typical soil contamination may be caused by spills onsite or are a result of an existing pollution problem that occurred prior to construction activities. Soils tend to get contaminated on projects in urban or industrial areas. Contaminated areas need to be identified in the project plans and specifications. During the project design stage, the site history should be investigated to ascertain potential soil contaminant problems.

Control Measures

The handling of existing contaminated soil should be addressed in the projects contract. Depending on the type of contamination, different handling requirements will need to be met. In some cases contaminated spoils may need to be placed in steel barrels, sealed and removed from the site. This waste will need to be taken to a licensed hazardous waste disposal site. Along with this, soil testing for contaminants in stormwater may be required at the discretion of the Construction, or Stormwater Inspector. The contractor's work needs to conform to appropriate local, state, and federal agencies to mitigate the contaminated soil.

Avoid stockpiling contaminated soils. If stockpiling is necessary and allowed, cover the stockpile with plastic sheeting or tarps, install a berm around the pile to prevent runoff for secondary containment, and locate the pile as far as possible (minimum 50 feet) from storm drains, natural waterways or drainage channels.

Pesticides and herbicides must be applied by a licensed applicator. Do not over-apply fertilizers or pesticides and follow product recommendations. Apply in small amounts, allowing product to absorb and dry prior to rain events. Check ingredient labels of fertilizers and pesticides and compare them with the U.S. EPA list of approved chemical treatment for soils. Many of the chemicals used for soil treatments, especial those used for termite control, are very toxic to aquatic life and are regulated by the EPA.

SOLID WASTE MANAGEMENT



Description

Materials that are collected and disposed of onsite in solid waste storage bins shall not come in contact with stormwater runoff. Solid wastes include such items as brick, mortar, timber, steel, plastics, landscaping waste, empty material containers and general construction litter.

Control Measures

Solid waste should be staged at a location which is least likely to be flooded, and at a location which is a minimum of 50 feet from a storm drain, natural waterway or drainage channel. Use berms, dikes or other temporary diversion structures to protect stockpiled waste from contacting stormwater. During rain events, waste materials need to be stored in watertight dumpsters and securely covered.

Provide adequate trash receptacles in the yard, field trailer areas and where workers gather for breaks or meals. Do not place litter receptacles or dumpsters near drainage inlets, natural waterways or drainage channels. All litter within the construction site should be collected weekly, regardless of the litter's origin. Litter needs to be removed from the site by a licensed solid waste contractor.

Make sure to provide an adequate amount of watertight dumpsters to collect the anticipated volume of construction waste. Also, plan for additional dumpsters to be delivered to the site and schedule additional dumpster pickups during demolition phases. Washing out dumpsters on the construction site is prohibited.

Do not allow litter to interfere with the storm drainage system. Ensure litter debris is removed regularly from drainage grates and ditch lines.

Separate out potentially hazardous waste from non-hazardous waste. Do not dispose of toxic liquid waste in dumpsters designated for construction wastes.

STOCKPILE MANAGEMENT



Description

Construction stockpiles of material such as soil, PCC, AC, aggregate base, aggregate sub-base and asphalt base cold mix (cutback) have the potential to pollute natural waterways.

Control Measures

Stockpile protection is a year round requirement. Install temporary barriers around stockpile perimeters to prevent contact with stormwater. Temporary barriers may be berms, dikes, silt fences, straw wattles, straw bales, and sand bag or gravel barriers. All active stockpiles should be protected by the use of linear-sediment barriers prior to rain events.

The key is to prevent contact between rainfall and runoff with stockpiles during the rainy season is to cover inactive and active material stockpiles and/or protect them with linear barriers prior to rain events. This includes stockpiles of PCC and AC rubble, aggregate base and aggregate sub-base.

If a soils stockpile is not going to be active for a long period of time, the site manager may want to consider hydro-seeding the pile and use vegetation to stabilize it. This control measure requires a lot less maintenance than keeping plastic sheeting in place over the pile. During the non-rainy season, cover or vegetate inactive stockpiles for dust control.

Place active and inactive cold-mix stockpiles on plastic sheeting or tarps, and cover them with plastic sheeting anchored down well prior to rain events.

MATERIAL USE, DELIVERY and STORAGE



Description

Construction materials should be delivered, stored and used in a manner to prevent them from polluting natural waterways. The project site manager needs to have available all Material Safety Data Sheets (MSDS) for all toxic materials and liquids used and stored on the site. Material lay-down areas need to be designed with drainage consideration in mind.

Control Measures

Maintain spill cleanup materials near areas where products will be used. Materials should be stored indoors in existing structures when available. Temporary storage sheds need to meet building and fire code requirements and should be located away from vehicle traffic. Storage instructions should be posted, and employees need to be trained in proper storage and delivery procedures.

Do not store hazardous materials on the ground. Store them on top of pallets in covered areas with secondary containment. Also, always store hazardous materials in their original containers with their original product labels attached. Do not store incompatible materials in the same temporary storage facility. Allow sufficient space between storage containers to allow for spill cleanup and emergency response access.

Ensure that adequate storage volume is provided and is located as far away as possible from storm drains, natural waterways and drainage channels (50 feet minimum). Temporary containment should be impervious to spilled wastes. Supply equipment storage areas with appropriate spill cleanup materials.

SPILL PREVENTION and CONTROL



Description

Spill prevention and prompt appropriate spill response reduces the potential for polluting natural waterways. Spills of concern include chemicals and hazardous waste such as soil stabilizers/binders, dust palliatives, herbicides, growth inhibitors, fertilizers, products, fuels, pesticides, lubricants, paints and solvents. Being prepared for a spill is very important.

Control Measures

Locate and clearly label spill-kits and disposal containers. Respond to all spills immediately. Appropriateness of the response is determined by the quantity and/or composition of the spilled substance as follows:

Minor Spill - Small quantity of oil, gas, paint, etc., that can be controlled by the first responder at the scene. The following should be done for a minor spill: contain the spill, recover the spilled material, clean the spill area and dispose of cleanup materials appropriately.

Semi Significant Spill - Can be controlled by the first responder with the aid of another person, and the spill may require the stopping of all other activity. On impermeable surfaces, surround the spill with absorbent material to contain it. Clean spill using absorbent material. On dirt areas, construct an earthen dike to contain the spill. Dig up contaminated soil and dispose of properly. If spill occurs in rain, cover spill area to prevent contaminating stormwater runoff.

Significant/Hazardous Spill - Significant spills cannot be controlled by personnel in the immediate vicinity. In the event of a significant spill the discharger should immediately call 911. Additionally, the discharger will need to call the City of Roseville's Stormwater Hotline (916) 774-1000, and the Governor's Office of Emergency Services Warning Center (805) 852-7550. For spills meeting federal quantities, the discharger will also need to notify the National Response Center (800) 424-8802. The discharger will need to obtain the services of a professional HazMat team immediately. Contractor's Staff should not attempt to cleanup until qualified assistance has arrived on-site.

APPENDIX (A) BMP Installation Details

INTENTIONALLY LEFT BLANK

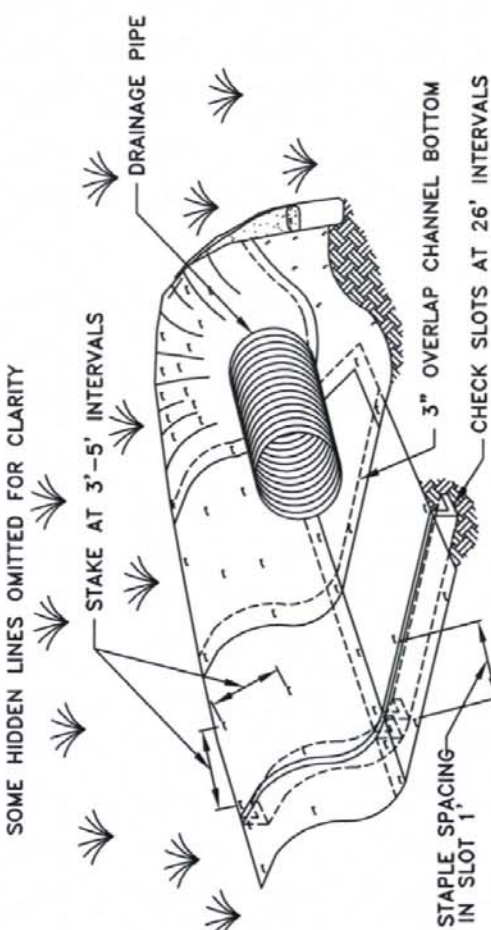

SOME HIDDEN LINES OMITTED FOR CLARITY

ISOMETRIC VIEW
TYPICAL CHANNEL
SOIL STABILIZATION
NTS

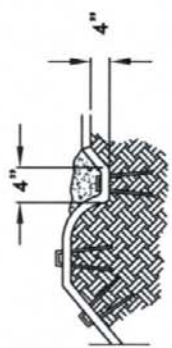

LONGITUDINAL
ANCHOR TRENCH
NTS

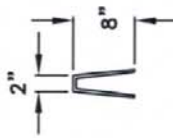

WIRE STAPLES
NTS

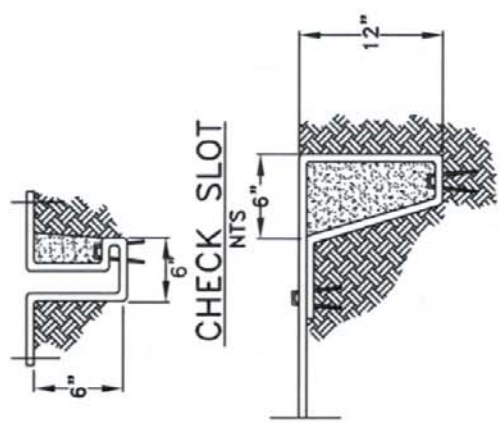

CHECK SLOT
NTS

INITIAL CHANNEL
ANCHOR TRENCH
NTS

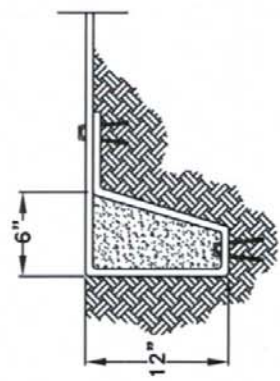

TERMINAL SLOPE AND
CHANNEL ANCHOR TRENCH
NTS

ROB JENSEN
DIRECTOR OF PUBLIC WORKS/CITY ENGINEER



MATS AND BLAKETS
CHANNEL INSTALLATION

SCALE: NONE
REVISED: APRIL 2007
DRAWN BY: STAFF
APPROVED BY: R JENSEN

NOTE:
1. CONSTRUCTION OF CHECK SLOTS STAKING, STAPLING LAYOUT, AND MAT INSTALLATION TO BE DONE PER MANUFACTURE'S RECOMMENDATIONS.

INTENTIONALLY LEFT BLANK

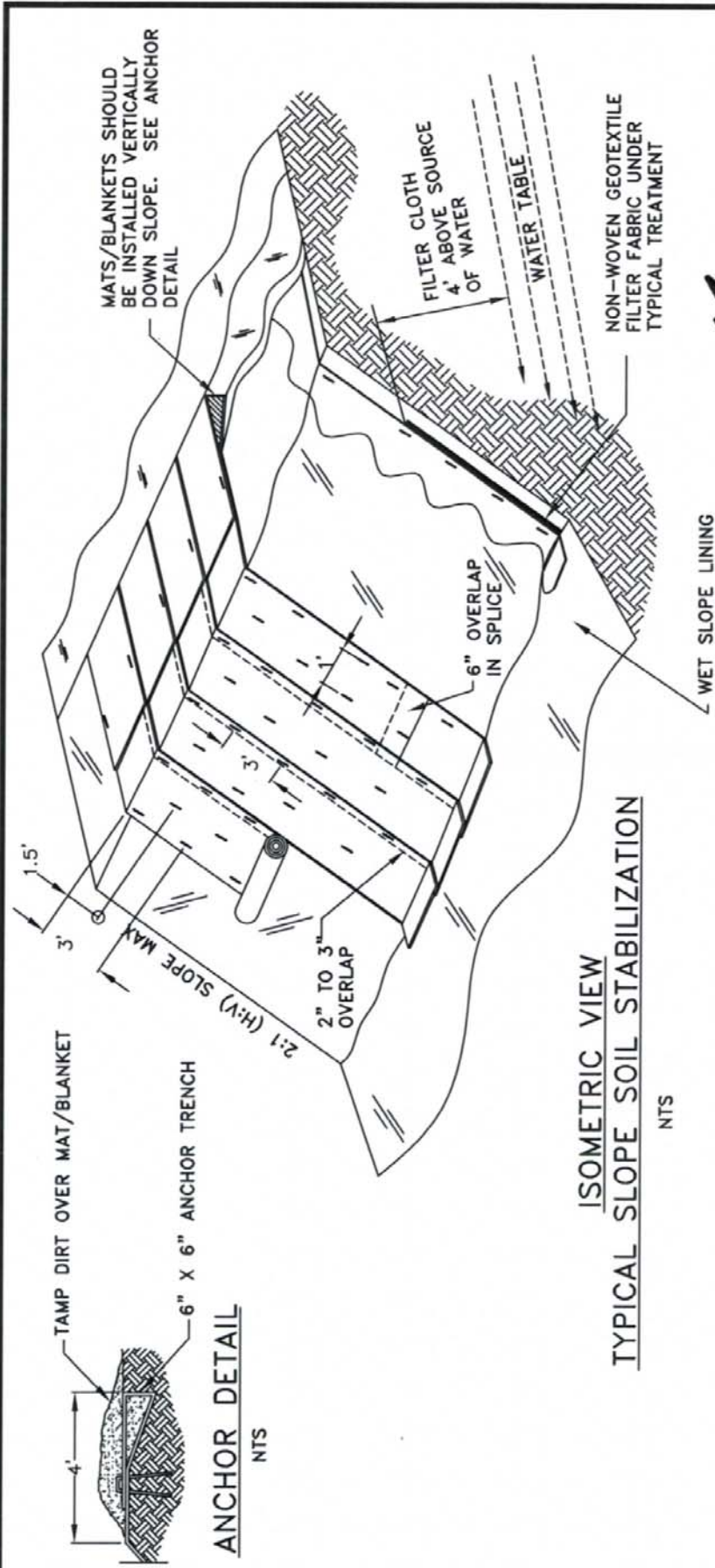

ROB JENSEN
DIRECTOR OF PUBLIC WORKS/CITY ENGINEER

	DEPARTMENT OF PUBLIC WORKS
	MATS AND GEOTEXTILE BLANKETS SLOPE INSTALLATION DETAIL
SCALE: NONE	BMP-2
REVISED: APRIL 2007	
DRAWN BY: STAFF	
APPROVED BY: R JENSEN	

- NOTES:
1. SLOPE SURFACES SHALL BE FREE OF ROCKS, CLODS, STICKS AND GRASS. MATS/BANKETS SHALL HAVE GOOD SOIL CONTACT.
 2. LAY BLANKETS LOOSELY AND STAKE OR STAPLE TO MAINTAIN DIRECT CONTACT WITH THE SOIL. DO NOT STRETCH.
 3. INSTALL PER MANUFACTURER'S RECOMMENDATIONS.

INTENTIONALLY LEFT BLANK

NOTES:

1. STABILIZE INLET, OUTLET, AND SLOPE.
2. PROPERLY COMPACT THE SUBGRADE.

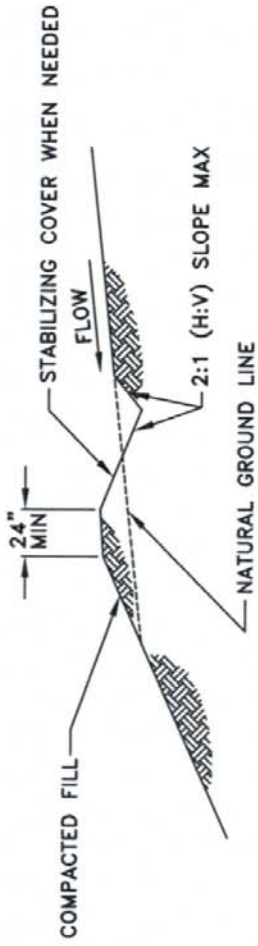

TYPICAL DRAINAGE SWALE

NTS

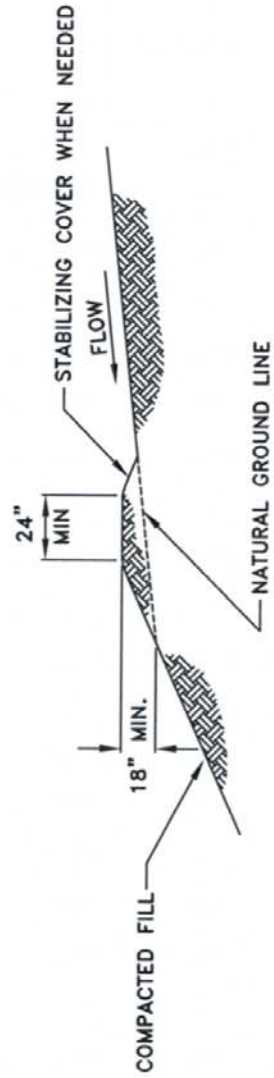

TYPICAL EARTH DIKE

NTS

ROB JENSEN
DIRECTOR OF PUBLIC WORKS/CITY ENGINEER



DEPARTMENT OF
PUBLIC WORKS

**EARTH DIKES AND SWALES
INSTALLATION DETAIL**

SCALE: NONE

REVISED: APRIL 2007

DRAWN BY: STAFF

APPROVED BY: R JENSEN

BMP-3

INTENTIONALLY LEFT BLANK

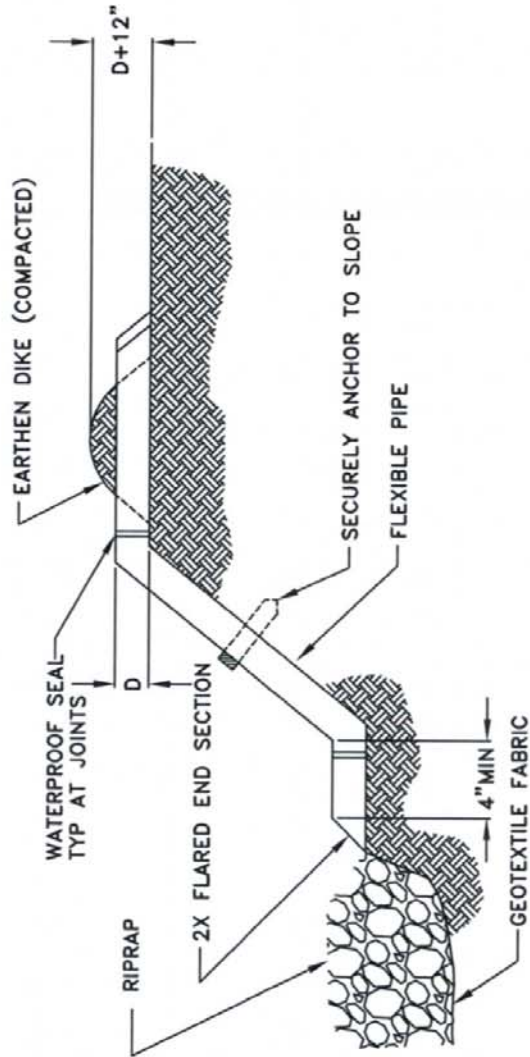

TYPICAL SLOPE DRAIN

NTS

ROB JENSEN
DIRECTOR OF PUBLIC WORKS/CITY ENGINEER



DEPARTMENT OF
PUBLIC WORKS

SLOPE DRIANS
INSTALATION DETAIL

SCALE: NONE
REVISED: APRIL 2007
DRAWN BY: STAFF
APPROVED BY: R JENSEN

BMP-4

INTENTIONALLY LEFT BLANK

VERTICAL SPACING MEASURED ALONG THE FACE OF THE SLOPE VARIES BETWEEN 8' - 20'

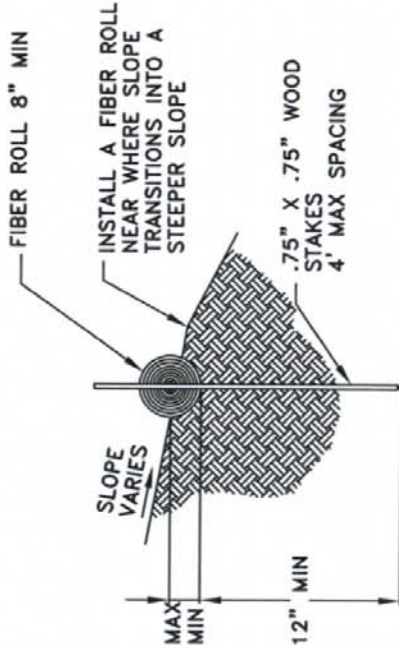
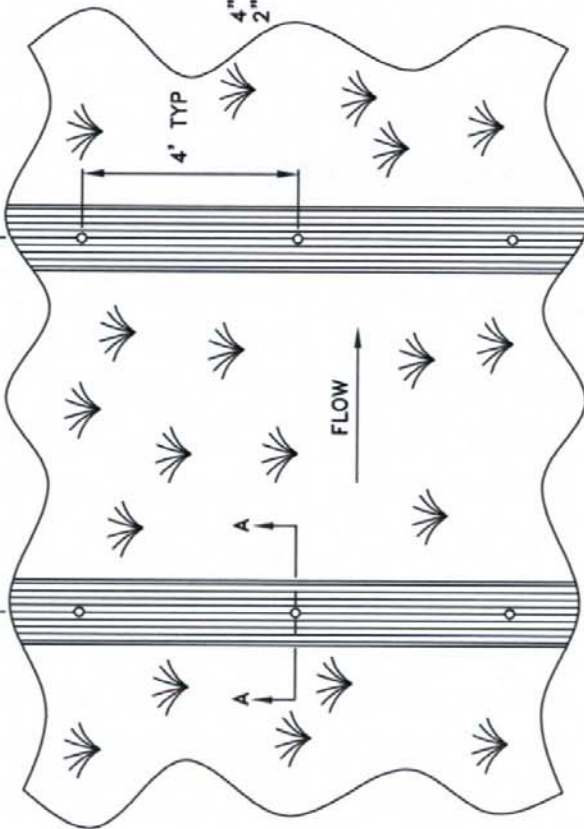

SECTION A-A
NTS

TYPICAL FIBER ROLL INSTALLATION
NTS

NOTES:

1. INSTALL FIBER ROLLS IN A ROW ALONG A LEVEL CONTOUR.
2. AT THE ENDS OF A ROW TURN THE LAST TWO FEET UP SLOPE SLIGHTLY.
3. AT JOINTS FIBER ROLLS SHALL BE OVERLAPPED, NOT ABUTTED.

[Signature]
ROB JENSEN
DIRECTOR OF PUBLIC WORKS/CITY ENGINEER

<p>CITY OF ROSEVILLE CALIFORNIA</p>	<p>DEPARTMENT OF PUBLIC WORKS</p>
	<p>FIBER ROLLS INSTALLATION DETAIL</p>
<p>SCALE: NONE REVISED: APRIL 2007 DRAWN BY: STAFF APPROVED BY: R JENSEN</p>	<p>BMP-5</p>

INTENTIONALLY LEFT BLANK

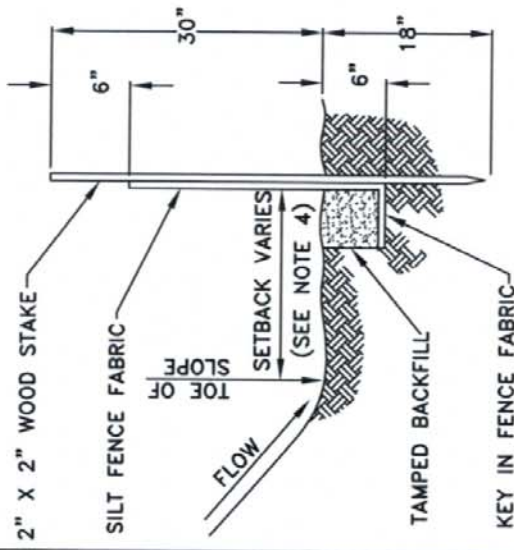

FENCE SECTION DETAIL
NTS

- NOTES:
1. CONSTRUCT THE LENGTH OF EACH REACH SO THAT THE CHANGE IN BASE ELEVATION ALONG THE REACH DOES NOT EXCEED 1/3 THE HEIGHT OF THE LINEAR BARRIER. IN NO CASE SHALL THE REACH LENGTH EXCEED 490'. THE LAST 8' OF FENCE SHALL BE TURNED UP SLOPE.
 2. STAKE DIMENSIONS ARE NOMINAL.
 3. DIMENSIONS MAY VARY TO FIT FIELD CONDITION.
 4. STAKES SHALL BE SPACED AT 8' MAX AND SHALL BE POSITIONED ON THE DOWNSTREAM SIDE OF THE FENCE.
 5. OVERLAP STAKES, AND FOLD FENCE FABRIC AROUND EACH STAKE ONE FULL TURN.
 6. STAKE SHALL BE DRIVEN TIGHTLY TOGETHER TO PREVENT POTENTIAL FLOW THROUGH OF SEDIMENT AT THE JOINT.
 7. FOR END STAKE CONDITION FOLD FENCE FABRIC AROUND (2) STAKES (1) FULL TURN AND SECURE WITH (4) STAPLES. MINIMUM (4) STAPLES PER STAKE.
 8. CROSS BARRIERS, SUCH AS SAND BAG DAMS, SHALL BE A MINIMUM OF 1/3 AND A MAXIMUM OF 1/2 THE HEIGHT OF THE SILT FENCE.
 - 9.
 - 10.

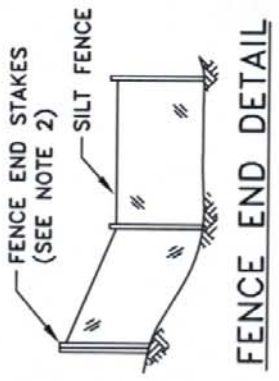

FENCE END DETAIL



STAPLE DETAIL
NTS

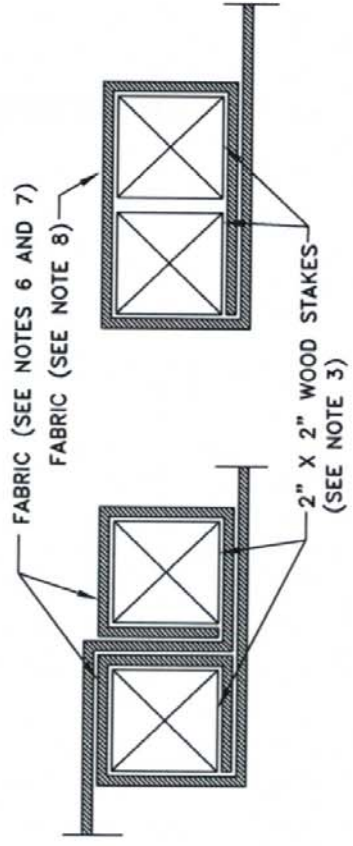

JOINT DETAIL

END STAKE DETAIL

ROB JENSEN
DIRECTOR OF PUBLIC WORKS/CITY ENGINEER



DEPARTMENT OF
PUBLIC WORKS

SILT FENCE
INFORMATION DETAIL

SCALE: NONE	BMP-6
REVISED: APRIL 2007	
DRAWN BY: STAFF APPROVED BY: R JENSEN	

INTENTIONALLY LEFT BLANK

GRAVEL BAG(S) OR OTHER ACCEPTED
SEDIMENT CONTROL BMP. PLACE BAGS
TIGHT AGAINST FACE OF CURB.

BACK OF CURB
FACE OF CURB

SEE NOTE 2

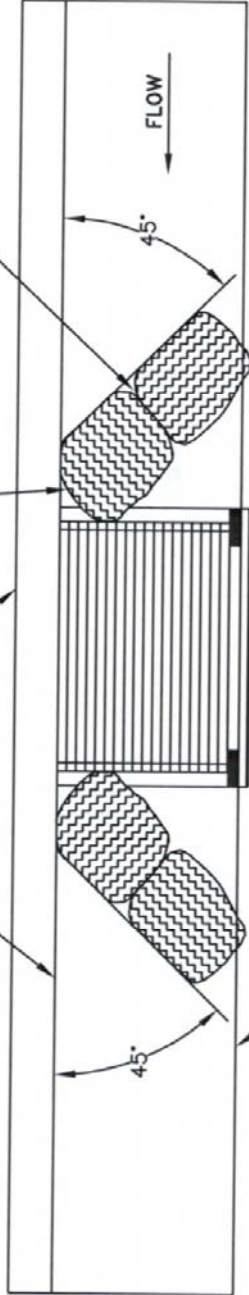

DRAINAGE INLET WITH FILTER BAG
(SEE BMP-8)

LIP OF GUTTER

PLAN VIEW

NOTES:

1. SEDIMENT TRAPPED UPSTREAM OF SEDIMENT CONTROL BMP SHALL BE REMOVED WEEKLY AND PRIOR TO A RAINFALL EVENT, OR AT THE DISCRETION OF THE PUBLIC WORKS INSPECTOR.
2. PLACE BMP'S TIGHTLY TOGETHER AT JOINTS TO PREVENT SEEPAGE AT JOINTS.
3. USE TO INHIBIT STORMWATER AND NON-STORMWATER FLOW.
4. SEDIMENT CONTROL MEASURES SHALL BE PROPERLY MAINTAINED, BY THE CONTRACTOR.

ROB JENSEN
DIRECTOR OF PUBLIC WORKS/CITY ENGINEER



DEPARTMENT OF
PUBLIC WORKS

INLET SEDIMENT CONTROL
INSTALLATION DETAIL

SCALE: NONE
REVISED: APRIL 2007
DRAWN BY: STAFF
APPROVED BY: R JENSEN

BMP-7

INTENTIONALLY LEFT BLANK

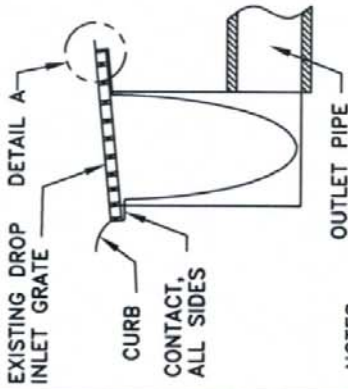

**PLACEMENT AT TYPE A,
C, D, AND F DROP INLETS
AND PARKING LOTS**

NTS

NOTES:

1. THE MAXIMUM DRAINAGE AREA PER FILTER SHALL BE NO MORE THAN 2 ACRES.
2. THE FILTER BAG SHALL BE MANUFACTURED FROM UV RESISTANT POLYPROPYLENE, NYLON, POLYESTER, OR ETHYLENE FABRIC WITH A MINIMUM TENSILE STRENGTH OF 50 LBS PER LINEAR FOOT, AN EQUIVALENT OPENING SIZE NOT GREATER THAN 20 SIEVE AND WITH MINIMUM FLOW RATE OR 40 GALLONS/ MINUTE/ SQ FT.
3. THE FILTER BAG MAY BE SUSPENDED FROM OR HELD IN PLACE BY THE EXISTING INLET GRATE (OR OTHER APPROVED METHOD), PROVIDED NO MODIFICATION OR DAMAGE SHALL BE DONE TO THE INLET GRATE OR FRAME. THE INLET GRATE SHALL NOT REST MORE THAN .5" ABOVE THE INLET FRAME (SEE DETAIL A)
4. THE FILTER BAG MAY EXTEND TO THE BOTTOM OF THE INLET BOX PROVIDED THE OUTLET PIPE IS UNOBSTRUCTED.
5. FLOWS SHALL NOT BE ALLOWED TO BYPASS THE BAG. THE BAG OR ITS FRAME SHALL CATCH FLOWS AT ALL SIDES OF THE INLET, EXCEPT AS SHOWN FOR FLOOD RELEASE.
6. INLET FILTER BAGS SHALL BE INSPECTED WEEKLY AND AFTER EACH RAINFALL DURING THE WET SEASON AND MONTHLY DURING THE DRY SEASON. SEDIMENT AND DEBRIS SHALL BE REMOVED BEFORE ACCUMULATIONS HAVE REACHED ONE THIRD THE DEPTH OF THE BAG. BAGS SHALL BE REPAIRED OR REPLACED AS SOON AS DAMAGE OCCURS. CONTRACTOR SHALL BE RESPONSIBLE FOR ALL MAINTENANCE.

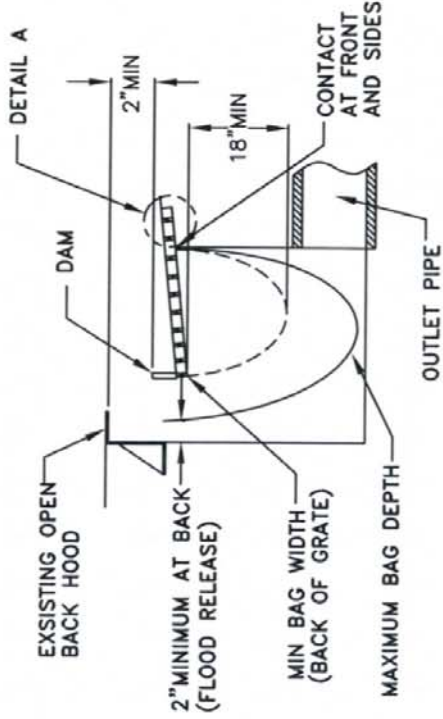

**PLACEMENT AT TYPE
B AND E DROP INLETS**

NTS

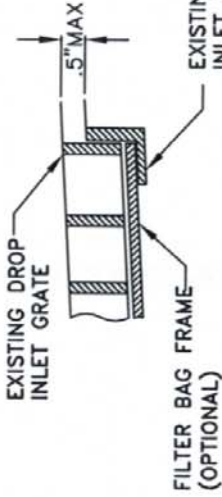

DETAIL A

ROB JENSEN
DIRECTOR OF PUBLIC WORKS/CITY ENGINEER



**DRAIN INLET FILTER BAG
INSTALLATION DETAIL**

SCALE: NONE
REVISED: APRIL 2007
DRAWN BY: STAFF
APPROVED BY: R JENSEN
BMP-8

INTENTIONALLY LEFT BLANK

NOTE:
 1. CONSTRUCT SEDIMENT BARRIER AND CHANNELIZE RUNOFF TO SEDIMENT TRAPPING DEVICE

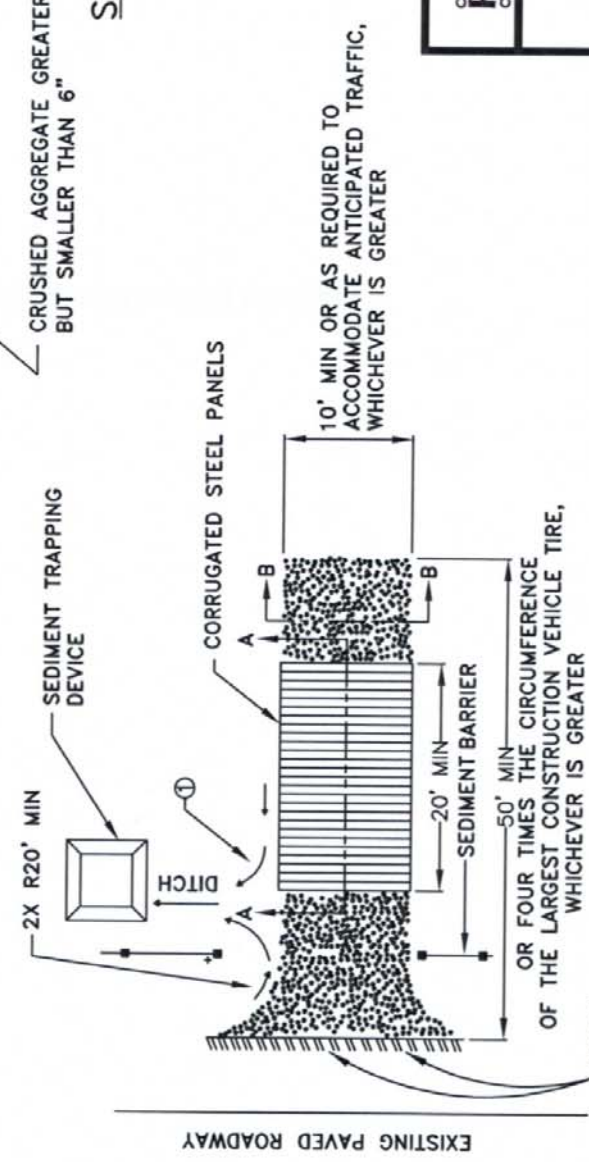
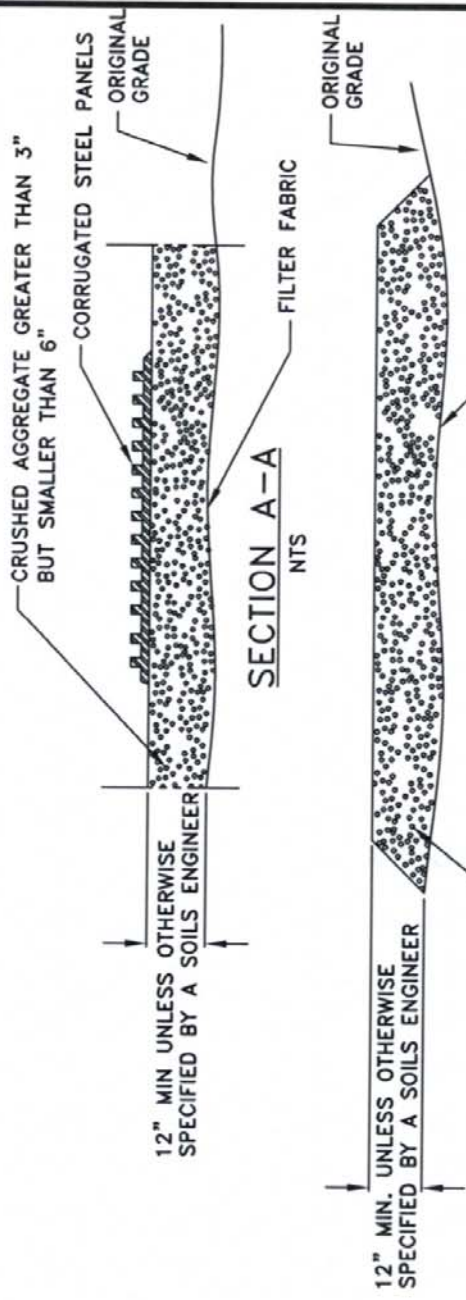

PLAN
 NTS

SECTION B-B
 NTS

[Signature]
 ROB JENSEN
 DIRECTOR OF PUBLIC WORKS/CITY ENGINEER

	DEPARTMENT OF PUBLIC WORKS
	STABILIZED CONSTRUCTION SITE ACCESS DETAIL
SCALE: NONE REVISED: APRIL 2007 DRAWN BY: STAFF APPROVED BY: R JENSEN	BMP-9

INTENTIONALLY LEFT BLANK

NOTES:

1. ACTUAL LAYOUT DETERMINED IN FIELD
2. THE CONCRETE WASHOUT SIGN SHALL BE INSTALLED WITHIN 30' OF THE TEMPORARY CONCRETE WASHOUT FACILITY.
3. WASHOUT BASIN SHALL BE MAINTAINED IN GOOD CONDITION BY THE CONTRACTOR.
4. WHEN NEEDED, PLASTIC LINING AND DRY RESIDUE SHALL BE REMOVED AND PROPERLY DISPOSED OF AND A NEW LINER INSTALLED.

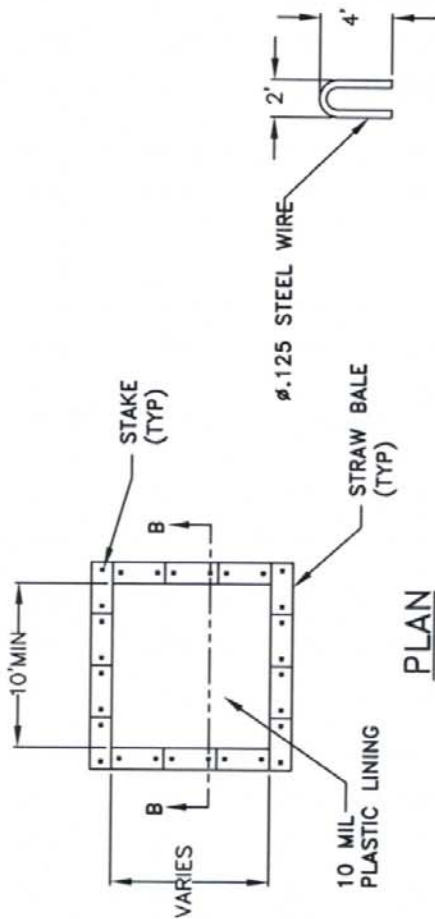

PLAN
ABOVE GRADE WASHOUT
WITH STRAW BALES
 NTS
STAPLE DETAIL
 NTS

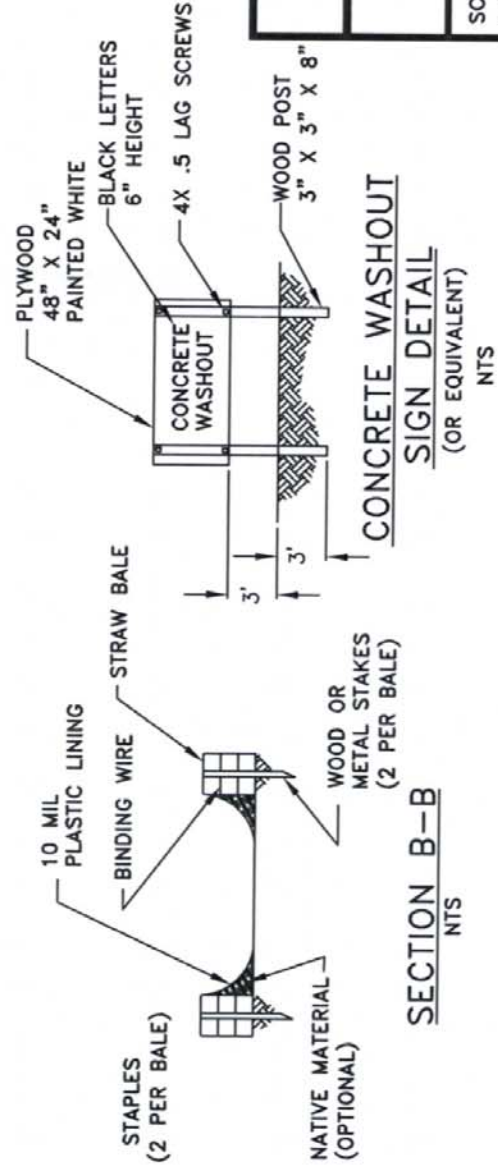

SECTION B-B
 NTS
CONCRETE WASHOUT
SIGN DETAIL
 (OR EQUIVALENT)
 NTS

ROB JENSEN
 DIRECTOR OF PUBLIC WORKS/CITY ENGINEER

CITY OF
ROSEVILLE
 CALIFORNIA
 DEPARTMENT OF
 PUBLIC WORKS

CONCRETE WASHOUT
INSTALLATION

SCALE: NONE
 REVISED: APRIL 2007
 DRAWN BY: STAFF
 APPROVED BY: R JENSEN
BMP-10

INTENTIONALLY LEFT BLANK

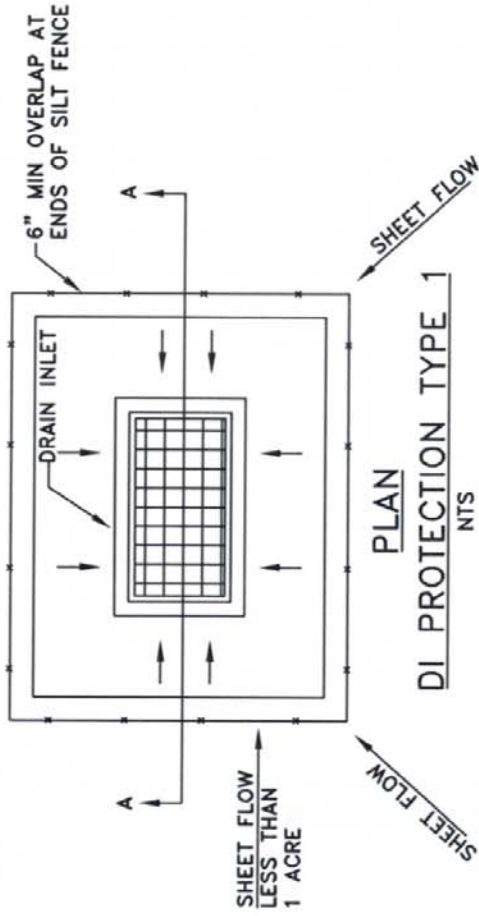
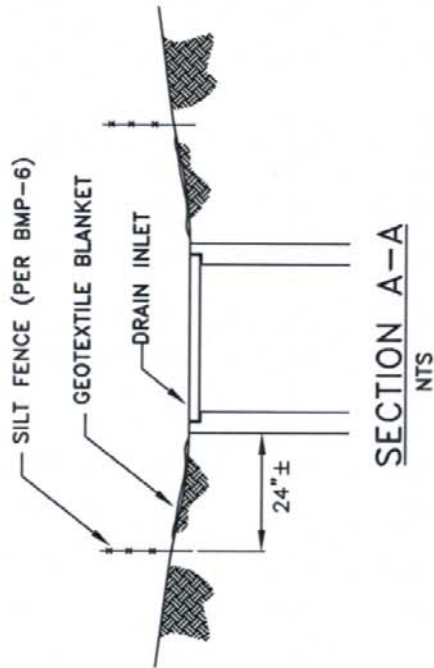

NOTES:

1. FOR USE IN AREAS WHERE GRADING HAS BEEN COMPLETED AND FINAL SOIL STABILIZATION AND SEEDING ARE PENDING.
2. NOT APPLICABLE IN PAVED AREAS.
3. NOT APPLICABLE IN CONCENTRATED FLOWS.

[Signature]
 ROB JENSEN
 DIRECTOR OF PUBLIC WORKS/CITY ENGINEER

CITY OF
ROSEVILLE
 CALIFORNIA
 DEPARTMENT OF
 PUBLIC WORKS

**STORM DRAIN INLET
 PROTECTION INSTALLATION**

SCALE: NONE
 REVISED: APRIL 2007
 DRAWN BY: STAFF
 APPROVED BY: R JENSEN

BMP-11

INTENTIONALLY LEFT BLANK

APPENDIX (B)
City of Roseville SWPPP Inspection From

Development Services Department Construction Site Stormwater Runoff Control Inspection Form

Corrections required prior to next inspection?	No	Corrections completed from previous report?	Yes
WDID # :	5S31C000000	Date:	01/01/2011
City Wide Project # :	000000	Inspector:	Stormwater Inspector
Name:	Roseville Development	Inspection Type:	Weekly
Address:	123 Clean Street	Rain:	None
Owner/Developer:	Owner	Wind:	None

Inspection Conclusion

Site in Compliance?	Yes	Two or more back to back non-compliance:	N/A
Violations observed?	None	City of Roseville Notice of Violation (RNOV) issued?	N/A
Stop Work Order issued?	N/A	Have RNOV requirements been completed?	N/A
Fine issued:	N/A		

Sediment Discharge

Is there any evidence that sediment has been discharged previously from the site?	None
Is there any sediment currently being discharged from the site?	None
Any non-visible pollutant sampling required?	No

Inspection Comments

Inspection Checklist

Inspection Type	Check	Yes/No	DRP*
SWPPP	Routine BMP inspection and maintenance Documentation is on file	Yes	N/A
SWPPP	The SWPPP includes a current map that accurately Indicates BMP's installed at the site	Yes	N/A
SWPPP	The current SWPPP is complete	Yes	N/A
SWPPP	Amendments to the SWPPP are clearly documented and dated	Yes	N/A
SWPPP	SWPPP addresses the minimum BMP requirements	Yes	N/A
SWPPP	SWPPP signed and certified	Yes	N/A
SWPPP	SWPPP binder and/or Erosion & Sediment Control Plan on site and accessible	Yes	N/A
Soil Stabilization	Site is free of erosion	Yes	None
Soil Stabilization	BMP materials are stockpiled and available for use	Yes	N/A
Soil Stabilization	Implemented BMPs are effectively stabilizing soil	Yes	None
Soil Stabilization	BMPs are implemented on inactive disturbed areas	Yes	None
Sediment	Storm drain inlets are protected	Yes	None
Sediment	BMPs adequately control sediment	Yes	None

Inspection Type	Check	Yes/No	DRP*
Sediment	Sediment BMPs are place to protect the Downstream perimeter of the site	Yes	None
Sediment	Sediment control BMPs are in place and maintained	Yes	None
Tracking	Current BMPs are effectively preventing tracking of sediment	Yes	None
Tracking	Adjacent roads and construction entrances are free of sediment	Yes	None
Wind Erosion	Current BMPs are adequately preventing wind Erosion	Yes	N/A
Wind Erosion	Wind erosion controls are properly implemented	Yes	N/A
Non-Stormwater	Sampling locations are noted in SWPPP	Yes	N/A
Non-Stormwater	Hydrant flushing protection	Yes	N/A
Non-Stormwater	No evidence of a non-stormwater discharge	Yes	N/A
Non-Stormwater	BMPs are adequate for managing non-stormwater Discharge	Yes	N/A
Non-Stormwater	BMPs for non-stormwater discharge are properly Implemented	Yes	N/A
Waste and Disposal	Advance water treated discharge meets water quality standards	Yes	N/A
Waste and Disposal	Portable toilets are placed behind sidewalks	Yes	N/A
Waste and Disposal	Portable toilets are located 50 ft. from DIs	Yes	N/A
Waste and Disposal	Current waste management BMPs are adequate	Yes	N/A
Waste and Disposal	Waste is adequately covered	Yes	N/A
Waste and Disposal	Construction debris is in waste containers	Yes	N/A
Waste and Disposal	Containers for construction waste and debris in-Place	Yes	N/A
Material Storage	Hazardous materials are placed in secondary Containment	Yes	N/A
Material Storage	Materials are stored away from drain inlets	Yes	N/A
Material Storage	Materials are protected from weather	Yes	N/A

*DRP Discharge Risk Potential

INTENTIONALLY LEFT BLANK

APPENDIX (C)
City Enforcement Procedures for SWPPP

INTENTIONALLY LEFT BLANK

City of Roseville Enforcement Procedures (SWPPP Violations)

Background

The following enforcement procedures are intended to make a consistent uniform process of identifying and administering enforcement actions to those who violate Federal (NPDES), State (ORDER NO 2009-0009-DWQ), and City of Roseville (Ordinance Chapter 14.20), storm water quality regulations. Included are examples of discharge and non-discharge violations, both major and minor. Also included are a list of enforcement actions, criteria and guidance for issuing enforcement actions, a SWPPP enforcement flow chart, a SWPPP inspection report form, and a mock copy of a RNOV.

Discharge violations are categorized as either major or minor, as defined in this document. Major discharges are cited when a significant amount of sediment laden water has left the construction site and has drained directly into the “Waters of the United States”. Waters of the United States are defined by the USEPA as “All waters that are currently used, were used in the past, or may be susceptible to use in interstate or foreign commerce, including all waters subject to the ebb and flow of the tide. “Waters of the United States” include all surface watercourses and water bodies, all interstate waters and intrastate lakes, rivers, streams (including intermittent streams), mudflats, sand flats, wetlands, sloughs, prairie potholes, wet meadows, playa lakes, or natural ponds”. [See 40 CFR 122.2 for the complete definition]. The duration of major discharges can vary, but typically last through the entire storm event and shortly thereafter. Non-stormwater discharge examples include, but are not limited to, dewatering operations, waterline flushing, excessive irrigation, and over-watering for dust control. Paints, solvents, concrete wash water, water treating chemicals, and other pollutants which enter the “Waters of the United States” as defined above, and are quantified, qualify as a major discharge. Blatant or intentional illicit discharges are classified as major discharges and carry the most severe enforcement actions.

Minor discharges may include sediment laden water released in small amounts over a period of time. Discharges of this kind typically are not released directly into “Waters of the United States”, or the volume of the discharge is difficult to detect. Small continuing illicit discharges gone unaddressed may also be upgraded to a major discharge.

Other minor non-discharge SWPPP violations may include, but are not limited to, poor housekeeping efforts, improper material storage, poor waste management, tracking issues, poorly maintained concrete and mortar washouts, and poor installation or needed BMP’s when weather is threatening. Neglecting these examples could result in an illicit discharge if left unaddressed prior to and during a rain event. Citing these non-discharge SWPPP violations as major or minor depend on; how wide spread the issue is, how long the problem has existed or will exist. Citing the issue as a major or minor violation will be determined by the Director or his/her assigned agent.

(Enforcement Actions for SWPPP Violations)

Enforcement Action Types

- A. Non-compliant SWPPP inspections
- B. City of Roseville Notice of Violation (RNOV)
- C. Citations – 1st violation \$100.00, 2nd same violation \$200.00, 3rd same violation and
and there after \$500.00
- D. Stop Work Order
- E. Abatement by City at Developer/Contractor Cost
- F. Administrative and Inspection Staff Time Cost Reimbursement
- G. Contact the RWQCB

A Non-compliant SWPPP Inspections

- Issued when a major or minor violations have occurred
- Issued when minor violations go unaddressed
- Issued when pre-storm inspection reveals inadequate protection, indicating significant illicit discharge potential.

B City of Roseville Notice of Violation (RNOV)

- Issued as an initial written notice indicating repercussion should corrective actions not be implemented in a specific time frame.
- Issued at the discovery of an illicit discharge.
- Issued when the risk is major and likely that a discharge will occur.
- RNOV states Ordinance violation.
- RNOV states penalty if not remedied by date noted.
- Issued by certified mail, fax, and most importantly, by hand, directly to the project's responsible SWPPP person, as indicated in the SWPPP document.
- Parties copied: Developer, Owner, Senior Engineer, Open Space Manager, and the RWQCB if deemed necessary.
- Issued after two non-compliant SWPPP inspections.

C Citations

- Issued on the spot for blatant violations (Washing concrete, mud, paint, etc. into the City storm drain system or other "Waters of the United States").
- Issued for minor unaddressed illicit discharges.
- Issued to owners, developers, and subcontractors. Company names cited with the individual violator's name (Company employee) listed on the citation if applicable.
- Issued by mail to the owner/developer, general contractor, or sub-contractor when responsible SWPPP representative is not on the project site.
- May be issued to the owner (as the violator), when a project is managed by a hired construction management consultant. In these cases, citations will be mailed and faxed to the owner. The responsible SWPPP representative will also be listed on the citation.

(Enforcement Actions Continued)

D Stop Work Order

- Issued only after RNOV requirements are not met by specified time.
- Issued for major violations.
- Issued for significant illicit discharges.
- Defiance of a “Stop Work Order” can result in arrest by Roseville Police Department

E Abatement by City at Developer/Contractors Cost

- Ordered when a violation is severe and in need of immediate attention.
- Ordered only when the responsible party is unresponsive.
- Ordered only after the responsible party has been given the chance to respond, but declines to act in a responsible manner.

F Administrative and Inspection Staff Time Cost Reimbursement

- Administrative and inspection staff time costs to be applied to any enforcement actions that incur such costs.

G Contact the RWQCB

- The City reserves the right to contact the RWQCB at any time for any reason.
- The City may contact the RWQCB after two non-compliance SWPPP inspections.
- The City shall contact the RWQCB when City enforcement actions are either exhausted or deemed ineffective.
- RWQCB may contact City staff at any time inquiring on any project. City staff must provide facts and documents as required.

